

**NORMANN**

USER MANUAL

Meat grinder

**AMG-352**



## DEAR CUSTOMER!

**Attention!** Check for mechanical damage.  
Due to continuous improvement, there may be slight differences between the device you have purchased and the illustrations in the operating instructions.

Be careful! Read this User Manual carefully before using the device. Always refer to this manual if you have any questions about its operation.

## OVERVIEW

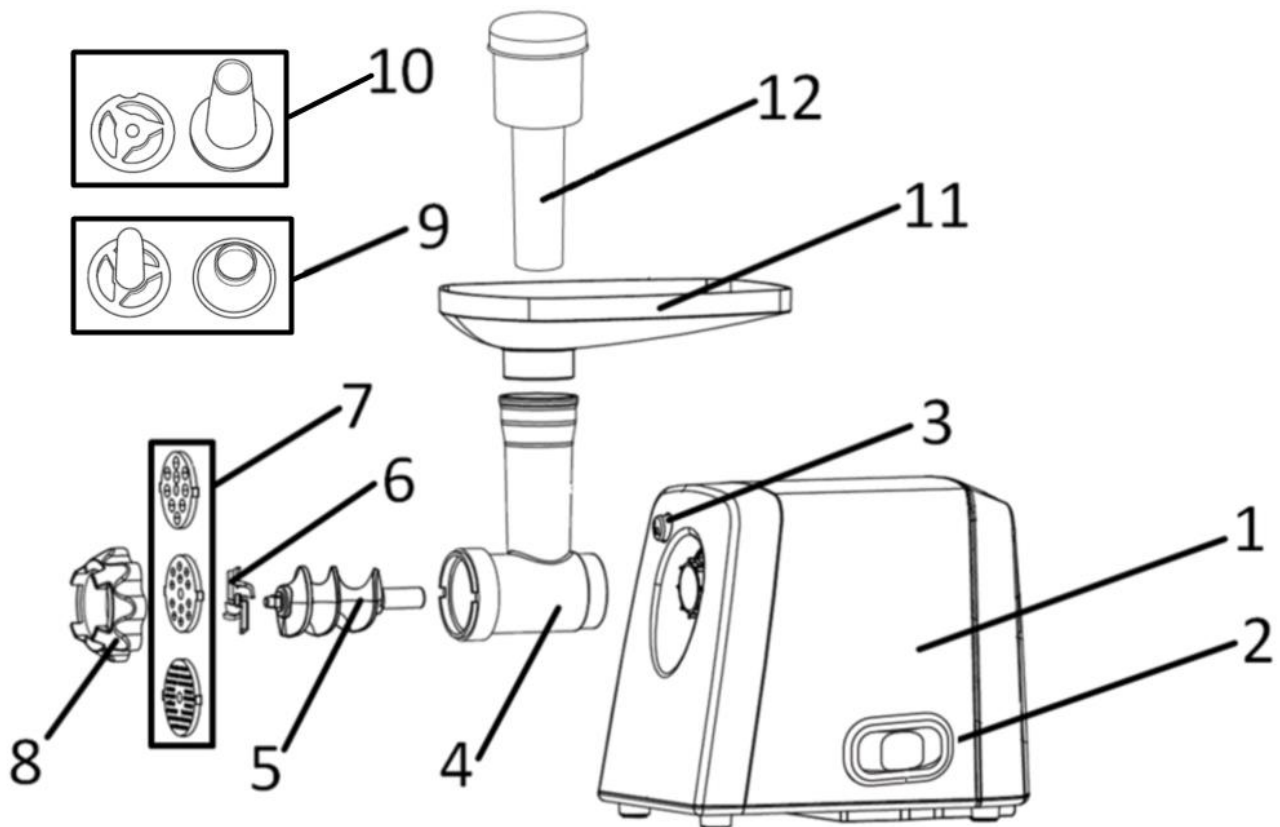

- 1 Enclosure with electric motor**
- 2 Switch (ON / O / R)\***  
\*On / Off / Reverse
- 3 Loading neck retainer**
- 4 Loading neck**
- 5 Auger**
- 6 Knife**
- 7 Grid with holes (3, 5, 7 mm)**

- 8 clamping nut**
- 9 Kebbe attachment**
- 10 Sausage maker attachment**
- 11 Loading tray**
- 12 Pusher with nozzle storage compartment**

**SAFETY RULES**

Read these operating instructions carefully before using the device. Use the device only for its intended purpose. Improper use may result in malfunction, damage to the user or damage to property.

The manufacturer is not liable for damage caused by non-compliance with the safety and operating instructions of the product.

Use the device only for processing soft foods, boneless meat, vegetables and fruits without bones. Do not process hard foods with the device: frozen foods, bones, nuts, etc.).

Only operate the appliance indoors. This appliance is intended solely for domestic use and is designed to cook a normal amount of food.

Do not use the appliance for other purposes for which it is not intended.

Improper use of the device is a source of potential injury. Do not use accessories that are not included in the package.

Do not use the device in an industrial environment or outdoors!

Do not operate the device outdoors - moisture or foreign objects entering the device case may cause serious damage to the device.

Do not use an aerosol can near the appliance.

Do not place the appliance on or in the immediate vicinity of an electric or gas stove. Do not place the appliance near open flames, appliances or equipment that are sources of heat.

Make sure that the operating parameters of your electrical system correspond to the voltage and power specified on the device.

Unplug the unit when you are not operating it or performing cleaning or maintenance procedures.

Do not connect the appliance to a shutdown timer.

Do not touch the device with wet hands.

Do not operate the device in bathrooms. Do not operate the device near open containers filled with water (swimming pool, tank, etc.)

During operation, make sure there are no sources of heat or open flames in the immediate vicinity.

Do not leave an operating device unattended.

Do not use various adapters or extension cords when plugging the unit into an outlet.

Operate the unit only with the original accessories that came with the unit.

Operate the device on a flat, stable surface. Do not place the device near the edge of a table.

When unplugging the device, hold only the plug of the power cord. Do not pull on the power cord to prevent damage.

Do not immerse the device in water or any other liquid. Failure to comply may result in electrical injury.

This appliance is not designed to be cleaned in a dishwasher.

Do not place the mains cable of the appliance near hot surfaces or sharp objects. Do not place heavy objects on the power cord. Position the power cord so that it cannot be stepped on or caught by your foot. Make sure that the power cord does not hang over the edge of a table or touch a hot surface.

Periodically check the condition of the power cord and plug for damage. Do not operate the device if there is any damage to the device parts, cord or plug.

If the power cord is damaged, it must be replaced by the manufacturer, the service department or similarly qualified personnel to avoid danger.

Do not operate the device if it is not working or if it is damaged. Do not disassemble or repair it yourself. Any technical operation must only be carried out by authorized service centers.

Never use accessories that are not supplied with this appliance or are not designed for this product.

Clean the device after each use. Refer to the instructions for the recommended method.

Do not use other methods including abrasive sponging, caustic agents, etc.

Do not pour water or other liquids inside the appliance.

Do not immerse the appliance body in water or under running water.

Use the carrying handle or by holding the housing to move the appliance. Do not move the unit by holding the tray or neck.

Do not move the device while it is running.

Do not touch moving parts of the device.

Do not push food into the neck with your fingers or other objects. Only use the original pusher included in the standard kit for this purpose.

The device is intended for domestic use only.

The device, including accessories, packaging materials and plastic bags must not be used by children as a toy. Children and people with disabilities may use the device only under supervision.

Before disassembling and servicing parts of the meat grinder, always make sure that the machine has come to a complete stop and is unplugged.

Careful! The cutting edges of the knife are sharply sharpened.

Do not reverse rotation (reverse) without ensuring that the auger has come to a complete stop. Failure to do so may result in damage to the unit.

Do not overload the device. If a blockage occurs, immediately stop the meat grinder, unplug it from the mains,

and clean the auger, throat and blade of the food that is blocking the process.

Continuous operation of the meat grinder should not exceed 7 minutes. After this time a break of 5-7 minutes is required to allow the motor to cool down.

**Warning.** Do not allow children to play with plastic bags or plastic wrap. Danger of suffocation!

The appliance is not intended for use by persons (including children) with reduced physical, sensory or mental capabilities, or lack of experience or knowledge, unless they have been given supervision or instruction concerning use of the appliance by a person responsible for their safety.

Children should be supervised to ensure that they do not play with the appliance.

---

## DESCRIPTION

The electric meat grinder is designed for grinding fresh and defrosted meat, as well as other non-solid products. The appliance is intended for domestic use. Any commercial use is prohibited.

**HelixMotion** spiral notch system inside the throat provides better performance than standard meat grinders.

**EasyClip** neck fastening system - easy and convenient maintenance after each use.

The model is equipped with a reversing function - an aid in operation.

The knife is made of high quality stainless steel.

---

## FIRST ACTIVATION

Carefully remove the product and its accessories from the box. Remove all packing materials and advertising labels (if any).

Be sure to keep the warning labels, warning stickers and the serial license plate on the product on site!

After transportation or storage of the device at a reduced temperature, keep the device at room temperature for at least two hours.

Place the device on a stable horizontal surface.

Wash all parts of the grinder that will come into contact with food with warm water and detergent. Assemble the appliance (see Assembly)

Before using the device for the first time, make sure that the data indicated on the device corresponds to your mains voltage.

Connect the device to the network. Make sure the device is turned off before connecting.

---

## ASSEMBLY

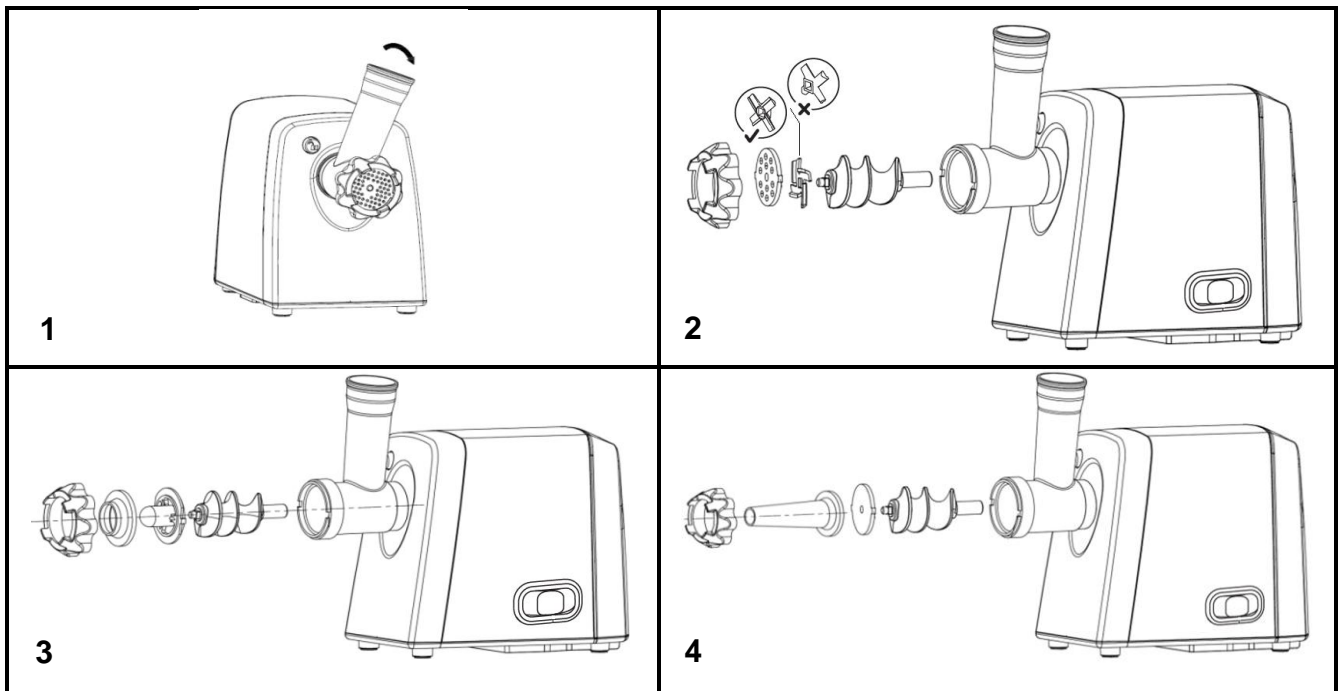

**Warning!** Do not start the motor before the meat grinder has been completely assembled.

- Insert the filler neck into the slot on the front panel at an angle of approximately 40-45 degrees clockwise from the vertical line. While pressing the lock button, rotate the filler neck counterclockwise until it clicks into place (Figure 1). Release the lock button. Check that the filler neck is securely locked.
- Insert the auger into the feeder neck with the long end facing inwards. Turn the auger slightly to lock it into the housing.
- Slide the blade onto the auger seat with the cutting side facing out.

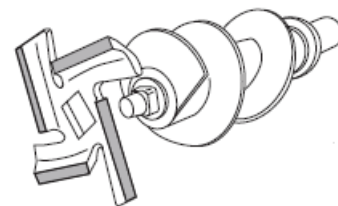

- Insert the grille just behind the knife, aligning the tabs on the grille with the grooves on the throat body.
- While holding the grille, screw the clamping nut on tightly. Do not use excessive force when tightening.
- Place the loading tray on the loading neck.

**EQUIPMENT.**

Cut the meat into pieces large enough to fit freely into the loading chamber.  
 Assemble the meat grinder as described in the Assembly section.  
 Connect the appliance to the mains. Before connecting, make sure that the meat grinder switch is in the off position (Off).  
 Turn the switch to the ON position.

Place the meat on the tray and feed it little by little into the feed opening. Use the pusher supplied for this purpose. After finishing work, turn the switch to the "O" position (Off), unplug the grinder and clean it.  
**Warning!** Operate cyclically: do not load the device for more than 7 minutes, then pause for at least 5 minutes. If the device overheats, allow it to cool down for 10 minutes.

**KEBBEH**

The kebbe attachment produces hollow tubes of minced meat, which can then be filled with stuffing and cooked. To prepare the meat grinder for making kebbeh, assemble as shown in Illustration 3. Install the filler neck.

**Attention!** For the preparation of kebbe tubes, pre-prepared minced meat must be used. Do not install a knife and grates or use whole pieces of meat for cooking. Place the minced meat on the tray. Pass it through the kebbe attachment. Divide the resulting tube into the required pieces. Fill the tubes with filling and close the ends. It is recommended to deep fry the kebbeh.

---

## SAUSAGE MAKING

To prepare the grinder for sausage making, assemble as shown in Illustration 4. then install the feeder neck.

**Attention!** Pre-prepared minced meat must be used for the sausage cooking operation. Do not install a knife and grates or use whole pieces of meat for cooking.

It is recommended to hold the shell in warm water for 10 minutes before the filling process.

Slide the casing onto the sausage maker attachment. Place the ground meat (minced meat) on the tray. Fill the casing with minced meat, gradually pushing the minced meat into the neck with the pusher.

---

## REVERSE

If the meat is stuck inside the chamber during operation, turn the switch to the "O" position (OFF), wait until all parts of the meat grinder come to a complete stop. Turn the switch to the REV (reverse) position and hold it. The motor will start to rotate the auger in the reverse direction and the clog will be removed.

If this procedure does not work, turn off and unplug the grinder and clean it (see CLEANING AND MAINTENANCE).

---











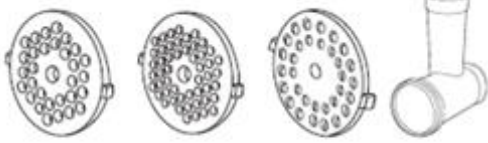



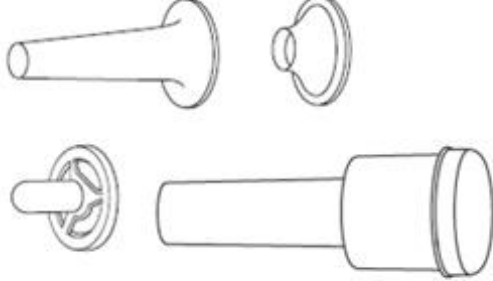

## OVERLOAD PROTECTION

The appliance is equipped with a safety system that switches it off in the event of an overload. If this happens, press the OFF button, disconnect the grinder from

the mains and allow it to cool down for 15-30 minutes. Clean the feeder part of the grinder of any food residues. The grinder will then be ready for use again.

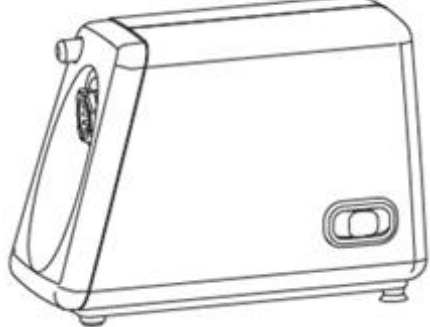
---

## CLEANING AND CARE

Disconnect the unit from the power supply before cleaning and maintenance. Perform regular care and maintenance to maintain the result.

**DO NOT** immerse the device housing in water or place it under running water!

Disassemble the grinder by following the procedure in the Reassembly section in reverse order.

To remove the filler neck, press the locking button, turn the neck clockwise.

Remove any food residues. Wash all parts that have come into contact with food with warm water and detergent. Do not use too hot water (over 50°C) to wash metal

parts, do not wash metal parts in the dishwasher. This may accelerate the oxidation of the metal.

Use a soft, non-abrasive damp sponge to wipe the surfaces of the unit. It is acceptable to use mild, non-abrasive cleaning agents. After care, wipe the surfaces dry with a soft cloth. Store additional attachments in the special storage compartment built into the pusher housing. It is recommended to lubricate all metal parts with vegetable oil during long-term storage.

Do not immerse the main body (with motor) in water or any other liquid and do not clean in a dishwasher. Failure to comply may result in electrical injury.

**SET**

1. Housing with electric motor - 1 pc.
2. Loading neck - 1 pc.
3. Loading tray - 1 pc.
4. Screw - 1 pc.
5. Knife - 1 pc.
6. Grid - 3 pcs.
7. Fixing nut - 1 pc.
8. Pusher - 1 pc.
9. Kebbe attachment - 1 comp.
10. Sausage maker attachment - 1 set.

## TECHNICAL PARAMETERS

Power supply: 220-240 V ~ 50 Hz  
 Rated power consumption: 500 W  
 Maximum power (with shaft lock): 1800 W  
 Protection class: II  
 Reverse function: yes  
 Continuous operation time: max. 7 min

## STORAGE AND TRANSPORTATION

Clean the mincing machine and dry it before storing it for a long period of time. Store all replaceable parts in the special compartment of the meat grinder. It is recommended to store the device in a cool, dry place out of the reach of children.

The meat grinder may be transported by any type of covered transport, excluding the possibility of mechanical damage from bumps or falls.

## FAULT DIAGNOSIS

Fault	Possible cause	Remedy
The meat grinder does not work	The power cord plug is not inserted into the power outlet	Insert the plug into the power outlet
	There is no voltage in the mains socket	Connect the device to a serviceable outlet
The meat grinder switches off prematurely	The device has overheated (continuous operation time exceeded)	Reduce continuous operation time
There's a peculiar odor	Presence of factory lubrication	After the first few times the odor will disappear

In all other cases, please contact the service department!

## UTILIZATION



If a product has a symbol with a crossed-out wheeled bin, this means that the product complies with European Directive 202/19/EU.

Familiarize yourself with your local separate collection system for electrical and electronic goods. Follow the local regulations.

Dispose of old devices separately from household waste. Proper disposal of your product will prevent possible negative consequences for the environment and human health.

This symbol on the product or on the original product documentation means that waste electrical and electronic equipment should not be disposed of with normal household waste. It should be taken to a specialized waste collection center for disposal and recycling. Proper disposal of this product will save valuable natural resources and



prevent harmful effects on the environment. Further information can be obtained by contacting your local information service or waste collection and recycling center. In accordance with local legislation, improper disposal of this type of waste may result in fines.

For information on the proper disposal of electrical or electronic equipment, contact your retail or wholesale outlet.

For information on the disposal of this product, please contact your local help desk or the place where you purchased it. This product complies with EU EMC and electrical safety requirements.

This product complies with all relevant major EU standards.

We reserve the right to change the manual text, design or product specifications without prior notice.

