

Top performance
with the lowest possible
power consumption.

High-frequency Production Tools
Full-range catalogue
www.boschproductiontools.com



BOSCH
Invented for life

High-frequency tools

Inexpensive power application



In spite of increasing automation in industrial production, the use of hand-held tools has advantages in many work operations. These tools have to meet several requirements: robustness, power and long lifetime, but also easy handling and high level of convenience.

Higher power due to higher frequency

Because their carbon brushes are subject to wear, universal motors of conventional power tools are unable to satisfy these requirements. On the other hand, the brushless asynchronous motor is ideally suited. The frequency it is supplied with determines its rotational speed, which, in turn, determines the output that can be achieved. A higher frequency therefore means a higher speed and a higher output.

High power at a constant speed

In continuous operation at 300 Hz, Bosch high-frequency tools have a power output of up to 400 watts per kg machine weight. Even brief peak powers of up to 2½ times this value are possible. The speed remains almost constant – irrespective of whether the tool is being operated at no-load or full-load.

Unique economy efficiency

Another argument in favour of high-frequency tools is their economic efficiency. Their degree of efficiency and therefore also their

energy consumption are unbeatably beneficial. Their long lifetime as well as their low maintenance requirements and power consumption offer an economic solution for every type of application.

Distinct environmental consciousness

The environmental factor is an important aspect of all Bosch products: from the initial development of the idea and energy saving products, to environmentally friendly packaging and disposal. If a Bosch high-frequency tool is irreparably damaged, Bosch will take back the old tool. They are collected centrally in the service centre and passed on for careful recycling.

Special energy saving measures

Bosch is also innovative in the area of power saving and places an emphasis on future-oriented technology: for example, in the Murrhardt plant, heat recycling saves more than half a million litres of heating oil per year.

Information from the Internet

Bosch now offers users and others interested in production tools all current product information on the Internet. Here you will find a free online catalogue illustrating in text and pictures all the common cordless, pneumatic and high-frequency tools for industrial use. More information on Page 4.

www.boschproductiontools.com

The frequency converters offered by our partner EME meet the standard VDE 0100 Part 410 Section 6.5 (galvanic isolation).



Conformity

All high-frequency tools listed in this catalogue conform with the following standards or standardised documents. EN 792, EN 60745, in accordance with the regulations of Directives 89/336/EEC, 98/37/EC.



Certified to ISO 9001
Certificate no.: FM 30078



Contents

High-frequency Grinders

- 06 Selection guide for grinders
- 10 Straight grinders
- 18 Angle grinders
- 24 Accessories for grinders, balancers, plug connections and cables
- 29 Dimensional drawings

High-frequency Technology

- 35 A guide for the user

An overview with one click: **All production tools online**

Operating instructions, pictures and dimensional drawings can be downloaded directly from the Internet.



Everything that users need to know can now be found on the Net: at www.boschproductiontools.com, a comprehensive online catalogue provides information on products and how they can be used. The selection of tools is made easier by the possibility to run comparisons between tools.

Users, for example, can display all high-frequency grinders and compare their respective data such as output or rotational speed. Furthermore, they can find out the latest news about trade-fair dates, innovations and new developments from the Bosch Production Tools Division.

Within a short time, this provides users with all the relevant information they need to select the correct production tools.

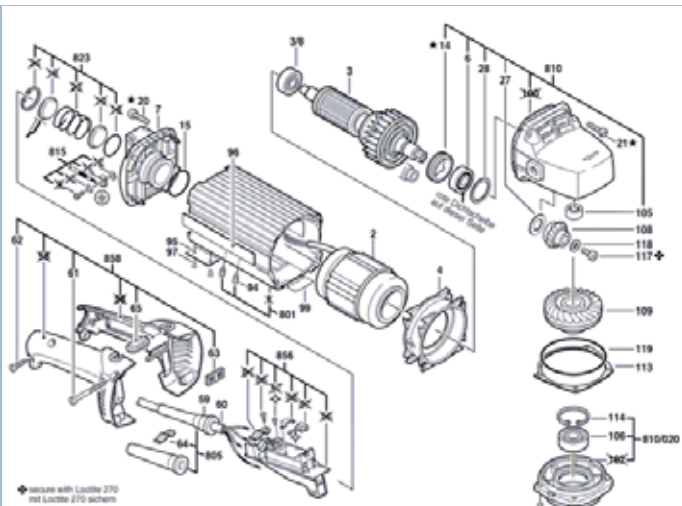

A spare parts service informs users about which spare parts they need – and where they can order them.

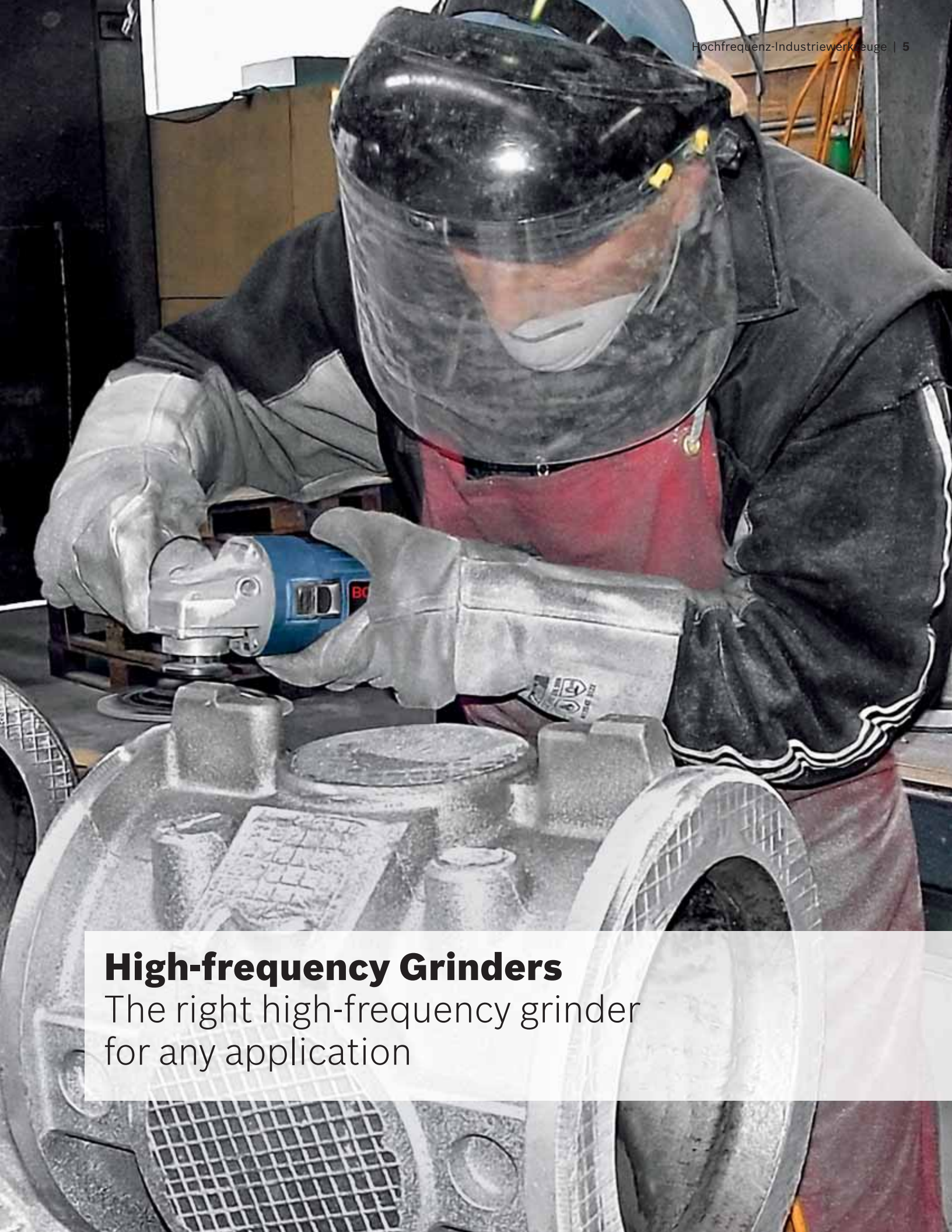

















High-frequency Grinders



The right high-frequency grinder
for any application

Selection guide for straight grinders

Selection of the right grinder is based on the range of application and the particular operation. This means that selection of the grinding bit is also associated with the choice of suitable grinder. For this reason, the suitable machines are assigned to the grinding work and grinding bits in the two tables for straight grinders and angle grinders. The more powerful the machine, the higher the material removal rate. However, due to the very different individual work conditions and ambient conditions, this recommendation can only be considered as a guideline. In any case, not only the power but also the other product features should be taken into consideration when selecting the grinder.

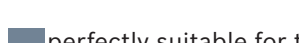
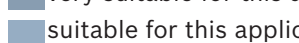
Please note the manufacturer's specifications on abrasives!

	Part number	No-load speed (rpm)
	0 602 238 1...	12 000
	0 602 207 4...	23 400
	0 602 208 4...	18 300
	0 602 208 4...	27 400
	0 602 209 4...	12 000
	0 602 209 4...	18 000
	0 602 210 4...	3 100
	0 602 210 4...	4 700
	0 602 211 4...	12 000
	0 602 211 4...	18 000
	0 602 245 0...	18 000
	0 602 211 5...	12 000
	0 602 211 5...	18 000
	0 602 243 1...	10 700
	0 602 212 4...	9 000
	0 602 242 1...	8 600
	0 602 242 2...	6 800
	0 602 213 4...	6 800
	0 602 240 1...	5 700

-  perfectly suitable for this application
-  very suitable for this application
-  suitable for this application



Selection guide for angle grinders

Selection of the right grinder is based on the range of application and the particular operation. This means that selection of the grinding bit is also associated with the choice of suitable grinder. For this reason, the suitable machines are assigned to the grinding work and grinding bits in the two tables for straight grinders and angle grinders. The more powerful the machine, the higher the material removal rate. However, due to the very different individual work conditions and ambient conditions, this recommendation can only be considered as a guideline.

In any case, not only the power but also the other product features should be taken into consideration when selecting the grinder.

Please note the manufacturer's specifications on abrasives!

	Part number	No-load speed (rpm)
	0 602 324 4...	4 800
	0 602 324 4...	5 800
	0 602 324 4...	6 800
	0 602 324 4...	7 300
	0 602 301 4...	4 100
	0 602 301 4...	6 150
	0 602 327 4...	2 550
	0 602 305 4...	1 750
	0 602 306 4...	1 650
	0 602 304 4...	5 700
	0 602 329 4...	8 500
	0 602 331 4...	8 500
	0 602 332 4...	6 600
	0 602 331 4...	6 600
	0 602 334 4...	6 600
	0 602 335 4...	4 700
	0 602 335 4...	5 100

-  perfectly suitable for this application
-  very suitable for this application
-  suitable for this application

Straight grinders

- ☒ The optimised straight grinders in all power classes for the widest possible variety of applications
- ☒ The ideal structural shape for ergonomic work
- ☒ Constant speed, even at extremely high loads
- ☒ Efficient work with longest possible lifetime
- ☒ Robust, durable motors with low maintenance costs
- ☒ Extremely favourable power/weight ratio

For grinding stones with 27-50 mm diameter

HGS 57/50 Ls



HGS 65/32



HGS 65/50



Part number	Voltage (V)	Frequency (Hz)	Permitted grinding stone diameter (mm)
0 602 238 101	265	200	50
0 602 238 104	135	200	50
0 602 238 107	72	200	50
0 602 238 134	200	300	50
<hr/>			
0 602 207 401	265	200	32
0 602 207 404	135	200	32
0 602 207 407	72	200	32
0 602 208 404	135	200	50
0 602 208 434	200	300	27
<hr/>			
0 602 209 401	265	200	50
0 602 209 404	135	200	50
0 602 209 407	72	200	50
0 602 209 434	200	300	50
0 602 209 411	72	300	50

The machines are supplied with a 4m long special cable without plug.

No-load speed (rpm)	Rated power input (W)	Rated power output (W)	Rated current (A)	Weight without cable (kg)	Toolholder, drive end, collet (mm)	Switch version	Comments	Comes complete with
12 000	400	270	1,6	2,1	6	Pressure switch with lock	Straight handle, central drive end Spindle length up to 480 mm possible	Collet diameter 6 mm Open-ended spanner KW 12 Open-ended spanner KW 15
12 000	400	270	3,3	2,1	6			
12 000	400	270	6,0	2,1	6			
18 000	600	400	3,3	2,1	6			
23 400	600	440	1,6	2,4	6	Safety switch	Straight handle, offset drive end	Collet diameter 6 mm Open-ended spanner KW 12 Open-ended spanner KW 15
23 400	600	440	3,3	2,4	6			
23 400	600	440	5,9	2,4	6			
18 300	600	440	3,3	2,4	6			
27 400	900	630	3,3	2,4	6			
12 000	600	440	1,6	2,5	6	Safety switch	Straight handle, central drive end	Collet diameter 6 mm Open-ended spanner KW 12 Open-ended spanner KW 15
12 000	600	440	3,3	2,5	6			
12 000	600	440	5,9	2,5	6			
18 000	900	630	3,3	2,5	6			
18 000	900	630	8,8	2,5	6			

Straight grinders

- ☒ The optimised straight grinders in all power classes for the widest possible variety of applications
- ☒ The ideal structural shape for ergonomic work
- ☒ Constant speed, even at extremely high loads
- ☒ Efficient work with longest possible lifetime
- ☒ Robust, durable motors with low maintenance costs
- ☒ Extremely favourable power/weight ratio

For grinding stones with 40–50 mm diameter

HGS 65/50



HGS 77/50



HGS 85/40



Part number	Voltage (V)	Frequency (Hz)	Permitted grinding stone diameter (mm)
0 602 210 401	265	200	50
0 602 210 404	135	200	50
0 602 210 434	200	300	50
<hr/>			
0 602 211 401	265	200	50
0 602 211 404	135	200	50
0 602 211 407	72	200	50
0 602 211 434	200	300	50
0 602 211 411	72	300	50
<hr/>			
0 602 245 034	200	300	40
0 602 245 011	72	300	40

The machines are supplied with a 4m long special cable without plug.

No-load speed (rpm)	Rated power input (W)	Rated power output (W)	Rated current (A)	Weight without cable (kg)	Toolholder, drive end, collet (mm)	Switch version	Comments	Comes complete with
3 100	600	440	1,6	2,5	6	Safety switch	Straight handle, offset drive end for polishing bit with low circumferential speed with flap discs with diameters up to 80 mm	Collet diameter 6 mm Open-ended spanner KW 12 Open-ended spanner KW 15
3 100	600	440	3,3	2,5	6			
4700	900	630	3,3	2,5	6			
12 000	950	700	2,8	4,3	8	Safety switch	Straight handle, central drive end	Collet diameter 8 mm Open-ended spanner KW 14 Open-ended spanner KW 22
12 000	950	700	5,5	4,3	8			
12 000	950	700	10,0	4,3	8			
18 000	1 450	1 050	5,5	4,3	8			
18 000	1 450	1 050	15,2	4,3	8			
18 000	1 800	1 500	6,4	4,7	Spindle M 14	Safety switch	Straight handle, central drive end for grinding bits with internal thread	Open-ended spanner KW 27
18 000	1 800	1 500	17,7	4,7	Spindle M 14			

Straight grinders

- ☒ The optimised straight grinders in all power classes for the widest possible variety of applications
- ☒ The ideal structural shape for ergonomic work
- ☒ Constant speed, even at extremely high loads
- ☒ Efficient work with longest possible lifetime
- ☒ Robust, durable motors with low maintenance costs
- ☒ Extremely favourable power/weight ratio

For grinding discs with 50–125 mm diameter

HGS 77/75



HGS 85/80



HGS 77/100



HGS 85/100



Part number	Voltage (V)	Frequency (Hz)	Permitted grinding disc diameter (mm)
0 602 211 501	265	200	75 mm ø
0 602 211 504	135	200	45 m/s
0 602 211 507	72	200	Circumferential speed
0 602 211 534	200	300	50 mm ø
			45 m/s
			Circumferential speed
0 602 243 134	200	300	80 mm ø
			45 m/s
			Circumferential speed
0 602 212 401	265	200	100 mm ø
0 602 212 404	135	200	45 m/s
0 602 212 407	72	200	Circumferential speed
0 602 242 101	265	200	100 mm ø
0 602 242 104	135	200	45 m/s
0 602 242 107	72	200	Circumferential speed
0 602 242 134	200	300	100 mm ø
			45 m/s
			Circumferential speed
0 602 242 234	200	300	125 mm ø
			45 m/s
			Circumferential speed

The machines are supplied with a 4m long special cable without plug.

No-load speed (rpm)	Rated power input (W)	Rated power output (W)	Rated current (A)	Weight without cable (kg)	Toolholder, drive end	Switch version	Comments	Comes complete with
12 000	950	700	2,8	4,7	Clamping flange M 14 for grinding bits with drilling diameter of 20 mm	Safety switch	The machine must not be operated without protective guard.	Open-ended spanner KW 32 Two-hole spanner Protective guard Backing flange Clamping flange
12 000	950	700	5,5	4,7				
12 000	950	700	10,0	4,7				
18 000	1 450	1 050	5,5	4,7				
10 700	1 800	1 500	6,4	5,5	Clamping flange M 14 for grinding bits with drilling diameter of 20 mm	Safety switch	The machine must not be operated without protective guard.	Open-ended spanner KW 32 Two-hole spanner Protective guard Backing flange Clamping flange
9 000	950	700	2,8	5,1	Clamping flange M 14 for grinding bits with drilling diameter of 20 mm	Safety switch	The machine must not be operated without protective guard.	Open-ended spanner KW 32 Two-hole spanner Protective guard Backing flange Clamping flange
9 000	950	700	5,5	5,1				
9 000	950	700	10,1	5,1				
8 600	1 200	1 000	3,3	5,5	Clamping flange M 14 for grinding bits with drilling diameter of 20 mm	Safety switch	The machine must not be operated without protective guard.	Open-ended spanner KW 32 Two-hole spanner Protective guard Backing flange Clamping flange
8 600	1 200	1 000	6,4	5,5				
8 600	1 200	1 000	11,8	5,5				
8 600	1 800	1 500	6,4	5,5				Open-ended spanner KW 32 Two-hole spanner Protective guard Backing flange Clamping flange
6 800	1 800	1 500	6,4	5,5				Open-ended spanner KW 32 Two-hole spanner

Straight grinders

- ☒ The optimised straight grinders in all power classes for the widest possible variety of applications
- ☒ The ideal structural shape for ergonomic work
- ☒ Constant speed, even at extremely high loads
- ☒ Efficient work with longest possible lifetime
- ☒ Robust, durable motors with low maintenance costs
- ☒ Extremely favourable power/weight ratio

For grinding discs with 125-180 mm diameter

HGS 77/125



HGS 88/150



Part number	Voltage (V)	Frequency (Hz)	Permitted grinding disc diameter (mm)
0 602 213 434	200	300	125 mm ø
			45 m/s
			Circumferential speed
0 602 240 104	135	200	150 mm ø
0 602 240 107	72	200	45 m/s
			Circumferential speed
0 602 240 134	200	300	150 mm ø
			45 m/s
			speed

The machines are supplied with a 4m long special cable without plug.

High-frequency	Rated power input (W)	Rated power output (W)	Rated current (A)	Weight without cable (kg)	Toolholder, drive end	Switch version	Comments	Comes complete with
6 800	1 450	1 050	5,5	5,2	Clamping flange M 14 for grinding bits with drilling diameter of 20 mm	Safety switch	The machine must not be operated without protective guard.	Open-ended spanner KW 32 Two-hole spanner Protective guard Backing flange Clamping flange
5 700	1 950	1 500	10,0	7,7	Clamping flange M 14 for grinding bits with drilling diameter of 20 mm	Safety switch	The machine must not be operated without protective guard.	Open-ended spanner KW 32 Two-hole spanner Protective guard Backing flange Clamping flange
5 700	1 950	1 500	18,0	7,7				
5 700	2 900	2 200	10,0	7,7				

Angle grinders

- ☒ The right grinder for every application
- ☒ Extremely robust and maintenance-friendly motors
- ☒ Constant speeds throughout the whole power range for top economy and longest possible lifetime
- ☒ Robust angular gears with high running performance and running smoothness

For grinding discs with 100–180 mm diameter

HWS 5265/125



Part number	Voltage (V)	Frequency (Hz)	Permitted grinding disc diameter (mm)
0 602 324 401	265	200	125
0 602 324 404	135	200	125
0 602 324 407	72	200	125

HWS 5265/125



0 602 324 441	265	200	125
0 602 324 444	135	200	125
0 602 324 447	72	200	125
0 602 324 464	135	200	125
0 602 324 474	135	200	125
0 602 324 434	200	300	125

HWS 65/125



0 602 301 401	265	200	125
0 602 301 404	135	200	125
0 602 301 407	72	200	125
0 602 301 434	200	300	125
0 602 327 401	265	200	100

HWS 77/175



0 602 305 401	265	200	175
0 602 305 404	135	200	175
0 602 305 407	72	200	175
0 602 306 434	200	300	175

HWS 77/180



0 602 304 401	265	200	180
0 602 304 404	135	200	180
0 602 304 407	72	200	180

The machines are supplied with a 4m long special cable without plug.

No-load speed (rpm)	Rated power input (W)	Rated power output (W)	Rated current (A)	Weight without cable (kg)	Toolholder, drive end	Switch version	Comments	Comes complete with
4 800	520	360	1,6	2,0	Clamping flange M 14 for grinding bits with drilling diameter of 22.2 mm	Slide switch	For fibre sanding sheets with spindle lock. SDS-click as special accessory	Two-hole spanner Auxiliary handle Round nut Backing flange
4 800	520	360	3,2	2,0				
4 800	520	360	6,0	2,0				
5 800	520	360	1,6	2,2	Clamping flange M 14 for grinding bits with drilling diameter of 22.2 mm	Slide switch	For light-duty grinding work	Protective guard diameter 125 mm Two-hole spanner Auxiliary handle Round nut Backing flange
5 800	520	360	3,2	2,2				
5 800	520	360	6,0	2,2				
5 800	520	360	3,2	2,2				
6 800	520	360	3,2	2,2				
7 300	800	550	3,2	2,2			For flap discs	
4 100	600	440	1,6	3,0	Clamping flange M 14 for grinding bits with drilling diameter of 22.2 mm	Safety switch	For fibre sanding sheets	Open-ended spanner KW 17 Auxiliary handle Two-hole spanner
4 100	600	440	3,3	3,0				
4 100	600	440	5,9	3,0				
6 150	900	630	3,3	3,0				
2 550	600	410	1,6	3,0				
1 750	950	700	2,8	4,4	Clamping flange M 14 for grinding bits with drilling diameter of 22.2 mm	Safety switch	For polishing work	Open-ended spanner KW 17 Auxiliary handle
1 750	950	700	5,5	4,4				
1 750	950	700	10,0	4,4				
1 650	1 450	1 050	5,5	4,4				
5 700	950	700	2,8	4,6	Clamping flange M 14 for grinding bits with drilling diameter of 22.2 mm	Safety switch	For medium-duty grinding work	Protective guard diameter 180 mm Backing flange Round nut Two-hole spanner Open-ended spanner KW 17 Auxiliary handle
5 700	950	700	5,5	4,6				
5 700	950	700	10,0	4,6				

Angle grinders

- ☒ The right grinder for every application
- ☒ Extremely robust and maintenance-friendly motors
- ☒ Constant speeds throughout the whole power range for top economy and longest possible lifetime
- ☒ Robust angular gears with high running performance and running smoothness

For grinding discs with 180–230 mm diameter

HWS 85/180



Part number	Voltage (V)	Frequency (Hz)	Permitted grinding disc diameter (mm)
0 602 329 401	265	200	180
0 602 329 404	135	200	180
0 602 329 407	72	200	180
0 602 329 434	200	300	180
0 602 329 411	72	300	180

HWS 88/180



0 602 331 401	265	200	180
0 602 331 404	135	200	180
0 602 331 407	72	200	180
0 602 331 434	200	300	180

HWS 88/230



0 602 332 401	265	200	230
0 602 332 404	135	200	230
0 602 332 407	72	200	230
0 602 332 411	72	300	230
0 602 332 434	200	300	230

The machines are supplied with a 4m long special cable without plug.

No-load speed (rpm)	Rated power input (W)	Rated power output (W)	Rated current (A)	Weight without cable (kg)	Toolholder, drive end	Switch version	Comments	Comes complete with
8 500	1 200	1 000	3,3	5,6	Clamping flange M 14 for grinding bits with drilling diameter of 22.2 mm	Safety switch	For medium-duty grinding work. SDS-click as special accessory.	Protective guard diameter 180 mm Backing flange Round nut Two-hole spanner Open-ended spanner KW 17 Auxiliary handle
8 500	1 200	1 000	6,4	5,6				
8 500	1 200	1 000	11,8	5,6				
8 500	1 800	1 500	6,4	5,6				
8 500	1 800	1 500	17,7	5,6				
8 500	1 950	1 500	5,0	6,5	Clamping flange M 14 for grinding bits with drilling diameter of 22.2 mm	Safety switch	For medium-duty to heavy-duty grinding work. SDS-click as special accessory.	Protective guard diameter 180 mm Backing flange Round nut Two-hole spanner Open-ended spanner KW 17 Auxiliary handle
8 500	1 950	1 500	10,0	6,5				
8 500	1 950	1 500	18,0	6,5				
8 500	2 900	2 200	10,0	6,5				
6 600	1 950	1 500	5,0	7,0	Clamping flange M 14 for grinding bits with drilling diameter of 22.2 mm	Safety switch	For medium-duty to heavy-duty grinding work. SDS-click as special accessory.	Protective guard diameter 230 mm Backing flange Round nut Two-hole spanner Open-ended spanner KW 17 Auxiliary handle
6 600	1 950	1 500	10,0	7,0				
6 600	1 950	1 500	18,0	7,0				
6 600	2 900	2 200	27,0	7,0				
6 600	2 900	2 200	10,0	7,0				

Angle grinders

- ☒ The right grinder for every application
- ☒ Extremely robust and maintenance-friendly motors
- ☒ Constant speeds throughout the whole power range for top economy and longest possible lifetime
- ☒ Robust angular gears with high running performance and running smoothness

Angle grinders for grinding discs with 230–300 mm diameter

HWS 810/230



Part number	Voltage (V)	Frequency (Hz)	Permitted grinding disc diameter (mm)
0 602 334 401	265	200	230
0 602 334 404	135	200	230
0 602 334 407	72	200	230
0 602 334 434	200	300	230
<hr/>			
HWS 810/300			
0 602 335 001	265	200	300
0 602 335 004	135	200	300
0 602 335 007	72	200	300
0 602 335 034	200	300	300

HWS 810/300



The machines are supplied with a 4m long special cable without plug.

No-load speed (rpm)	Rated power input (W)	Rated power output (W)	Rated current (A)	Weight without cable (kg)	Toolholder, drive end	Switch version	Comments	Comes complete with
6 600	2 500	2 200	6,7	8,5	Clamping flange M 14 for grinding bits with drilling diameter of 22.2 mm	Safety switch	For heavy-duty grinding work. SDS-click as special accessory.	Protective guard diameter 230 mm Backing flange Round nut Two-hole spanner Open-ended spanner KW 17 Auxiliary handle
6 600	2 500	2 200	13,2	8,5				
6 600	2 500	2 200	24,7	8,5				
6 600	3 800	3 100	13,2	8,5				
4 700	2 500	2 200	6,7	10,0	Clamping flange M 14 for grinding bits with drilling diameter of 22.2 mm	Safety switch	For cutting work	Protective guard diameter 300 mm Backing flange Round nut Backing flange Allen key Two-hole spanner Open-ended spanner KW 17 Auxiliary handle
4 700	2 500	2 200	13,2	10,0				
4 700	2 500	2 200	24,7	10,0				
5 100	3 800	3 100	13,2	10,0				

Speed table for grinding bits

Permitted working speeds

Please note the following when using grinding stones: permitted speeds (rpm) depend on grinding bit diameter and length, as well as shank diameter and clamping length as per DIN 69170.

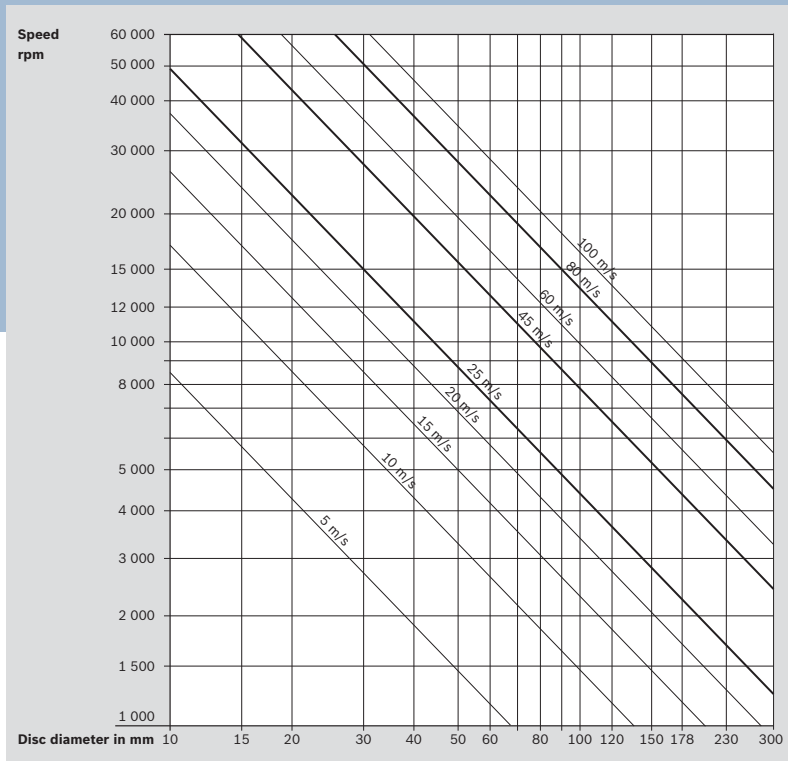

The table shows the relationship between the permitted diameter of the grinding discs and the speed.

Accessories for angle grinders

	Part number
Locking nut	1 603 345 043

	Part number	Version for type	Connecting thread
Vibration-damped handle	1 602 025 030	0 602 ...	M 14
	1 602 025 031	0 602 324...	M 10

Accessories for straight grinders

				0 602 207 401-407	0 602 211 401-411
				0 602 208 404-34	
				0 602 209 401-411	
				0 602 210 401-434	
				0 602 238 101-134	

Collet diameter					
6 mm				2 608 570 118	–
1/4"				–	2 608 570 014
8 mm				2 608 570 016	2 608 570 009
10 mm	–	–	–	–	2 608 570 017

	0 602 211 ... and 243 ...	0 602 212 ... and 242 ...	0 602 213 ...	0 602 240 ...	0 602 240 ...	0 602 239...
--	------------------------------	------------------------------	---------------	---------------	---------------	--------------

Accessories for conical grinding discs						
	45 and 80 m/s up to 80 mm ø	45 and 80 m/s up to 125 mm ø	45 m/s up to 125 mm ø	45 m/s up to 150 mm ø	80 m/s up to 150 mm ø	45 m/s up to 180 mm ø
Protective guard	3 605 510 025	3 605 510 031	3 605 510 030	3 605 510 028	3 605 510 031	3 605 510 035
Backing flange	3 605 703 028	3 605 703 028	3 605 703 068	3 605 703 068	3 605 703 068	3 605 703 068
Clamping flange	3 605 703 074	3 605 703 074	3 605 703 077	3 605 703 077	3 605 703 077	3 605 703 077
Permitted width of the grinding bit (mm)	20/25	20/25	20/25	20/25	20/25	20





	Part number	Version for type 0 602 ...	Length in mm
Spindle extension	3 606 120 031	... 238 101 up to 134	150
	3 606 120 032	... 238 101 up to 134	300

Balancers



Balancers

- ☒ Robust metal safety hanger including spring hook
- ☒ Bowden cable with high-quality distributor valve and safety coupling for uniform pulling out behaviour
- ☒ Spring fracture safety device for balancers with a load greater than 3 kg
- ☒ Cable change possible without disassembly of the spring drum
- ☒ Easy change of the weight class due to modular structure

For loads of 0.3 kg to 17 kg	Part number
Balancer 	0 607 950 920
Balancer 	0 607 950 921 0 607 950 922 0 607 950 923 0 607 950 931 0 607 950 937
Balancer 	0 607 950 924 0 607 950 925 0 607 950 926
Balancer 	0 607 950 927 0 607 950 928

Min. load (kg)	Max. load (kg)	Max. stroke (mm)	Weight (kg)	Comments
0.3	1.2	1 200	0.5	Retractor with adjustable load bearing range
0.6	1	2 000	0.7	Retractor with adjustable load bearing range
1	2	2 000	0.7	
2	3	2 000	0.8	
0.5	2	2 000	0.7	Retractor with adjustable load bearing range and lock
1.5	3	2 000	0.8	
3	5	2 000	3	Retractor with adjustable load bearing range
6	8	2 000	3.2	
8	10	2 000	3.4	
9	14	2 000	3.4	Balancer with adjustable load bearing range
13	17	2 000	3.6	

Plug connections and cables

CEE plug connections DIN 49 462/63 and DIN 49 465 for frequencies of 100–300 Hz (green housing)	Part number	Voltage (V)	Load capacity (A)	Packing unit
Coupling plug	1 614 482 048	50–300	16	1
	1 614 482 049	50–300	32	1
	1 614 482 050	up to 50	32	1
Coupling half	1 614 484 010	50–300	16	1
	1 614 484 011	50–300	32	1
Socket (surface-mounted version)	1 614 485 024	50–300	16	1

Electrical cables	Part number	Conductor cross-section (mm ²)	Outer diameter (mm)
4-wire cable (length 50 m)	3 604 422 077*	1.50	11
	3 604 422 050*	2.50	13
Working length 4 m (spiral cable)	3 604 462 002	0.75	8
Working length 6 m (spiral cable)	3 604 462 003	0.75	8

*non-packaged

Frequency converters are available at: EME GmbH · P.O. Box 0306 · D-76257 Ettlingen

Telephone 07243320606 · Fax 07243320611

Your specialist retailer can provide you with information on the complete range of quality accessories.

Dimensional drawings Straight grinders

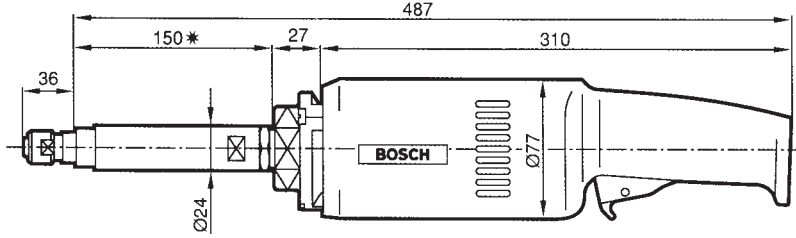
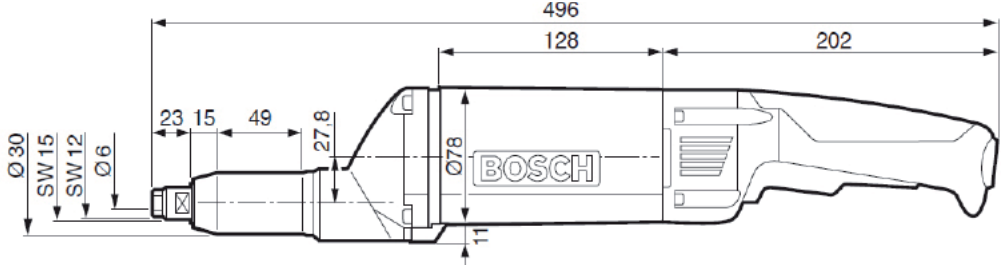
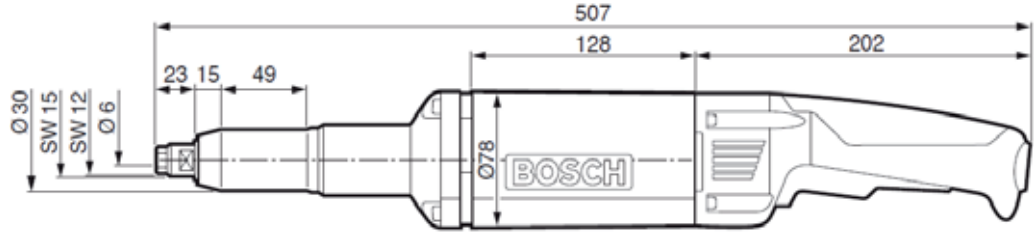
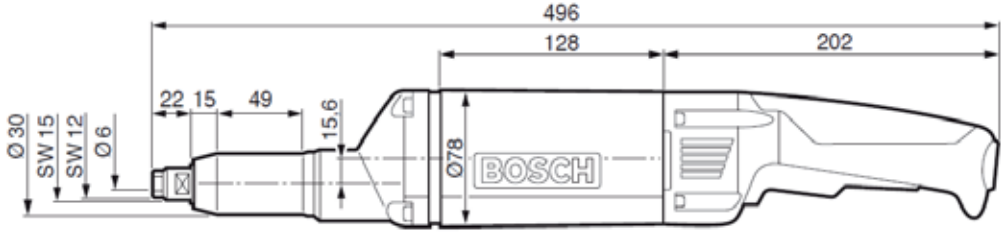
Dimensions in mm	Part number
	0 602 238 101 0 602 238 104 0 602 238 107 0 602 238 134
	0 602 207 401 0 602 207 404 0 602 207 407 0 602 208 404
	0 602 209 401 0 602 209 404 0 602 209 407 0 602 209 411 0 602 209 434
	0 602 210 401 0 602 210 404

Dimensional drawings

Straight grinders

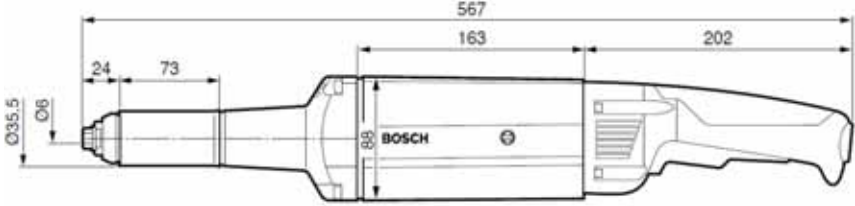
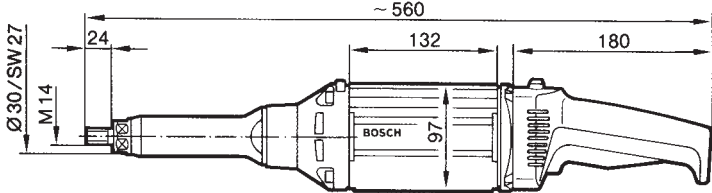
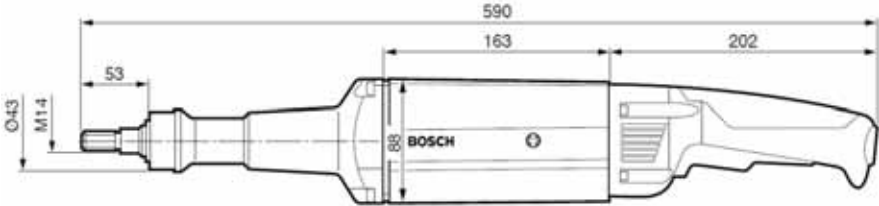
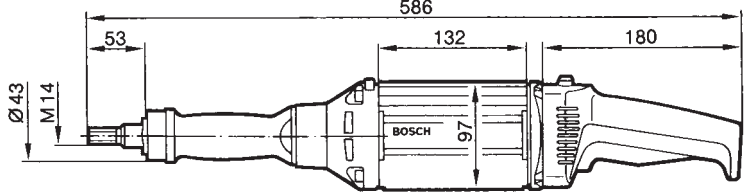
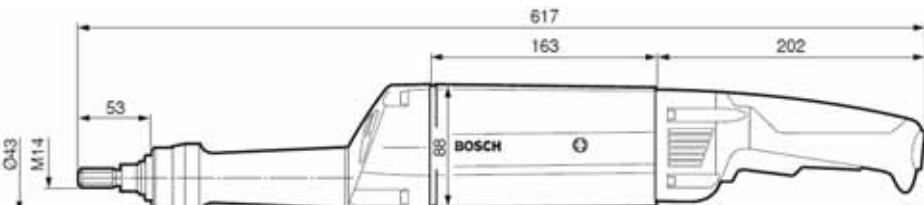
Dimensions in mm	Part number
	0 602 211 401 0 602 211 404 0 602 211 407 0 602 211 411
	0 602 245 011 0 602 245 034
	0 602 211 501 0 602 211 504 0 602 211 507 0 602 211 534
	0 602 243 134
	0 602 212 401 0 602 212 404 0 602 212 407

Dimensional drawings Straight grinders

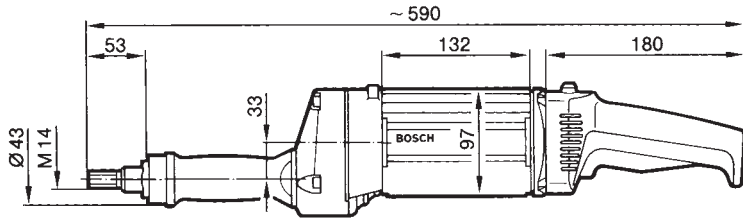
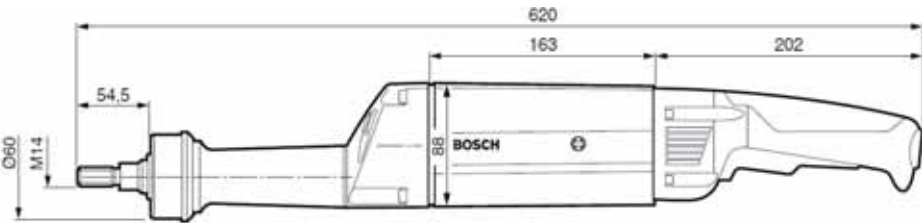
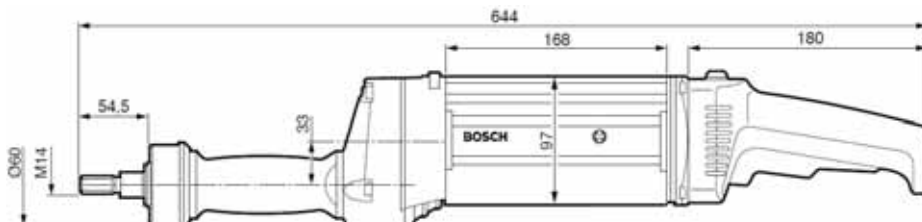
Dimensions in mm	Part number
	<p>0 602 242 101</p> <p>0 602 242 104</p> <p>0 602 242 107</p> <p>0 602 242 134</p> <p>0 602 242 234</p>
	<p>0 602 213 434</p>
	<p>0 602 240 104</p> <p>0 602 240 107</p> <p>0 602 240 134</p>

Dimensional drawings

Angle grinders

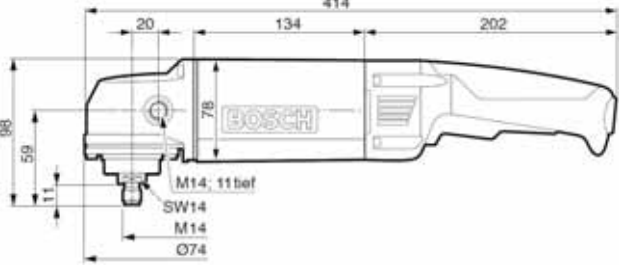
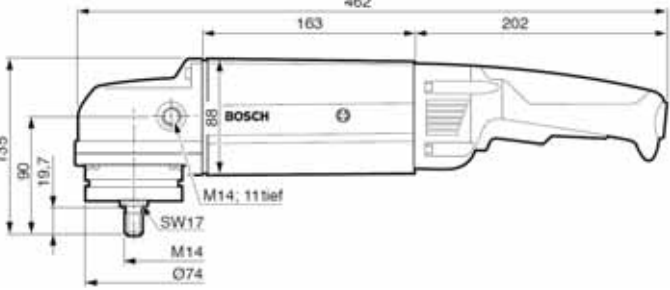
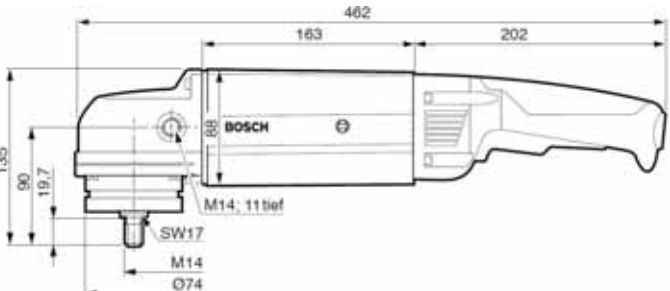
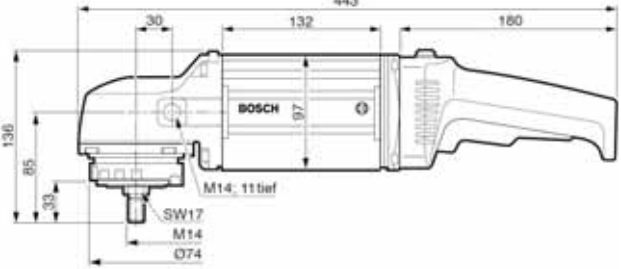
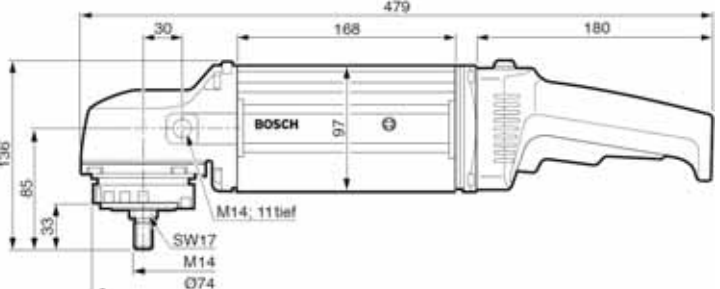
Dimensions in mm	Part number
	0 602 301 401 0 602 301 404 0 602 301 407 0 602 301 434 0 602 327 401
	0 602 304 401 0 602 304 404 0 602 304 407
	0 602 305 401 0 602 305 404 0 602 305 407 0 602 306 434
	0 602 329 401 0 602 329 404 0 602 329 407 0 602 329 411 0 602 329 434
	0 602 331 401 0 602 331 404 0 602 331 407 0 602 331 434 0 602 332 401 0 602 332 404 0 602 332 407 0 602 332 411 0 602 332 434

Dimensional drawings

Angle grinders

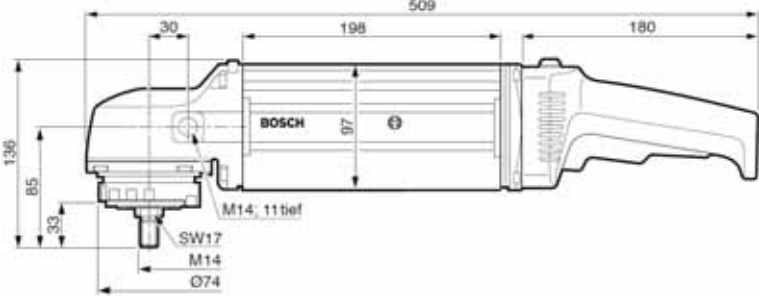
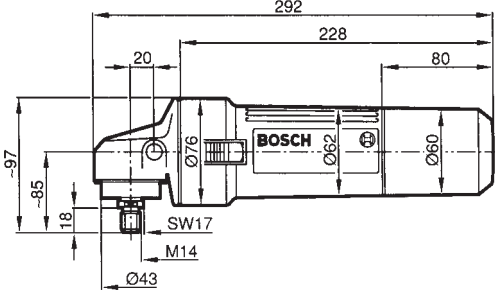
Dimensions in mm	Part number	
	0 602 334 401	
	0 602 334 404	
	0 602 334 407	
	0 602 334 434	
	0 602 335 001	
	0 602 335 004	
	0 602 335 007	
	0 602 335 034	
	0 602 324 401	
	0 602 324 404	
	0 602 324 407	
	0 602 324 441	
	0 602 324 444	
	0 602 324 447	
	0 602 324 434	
	0 602 324 464	
	0 602 324 474	

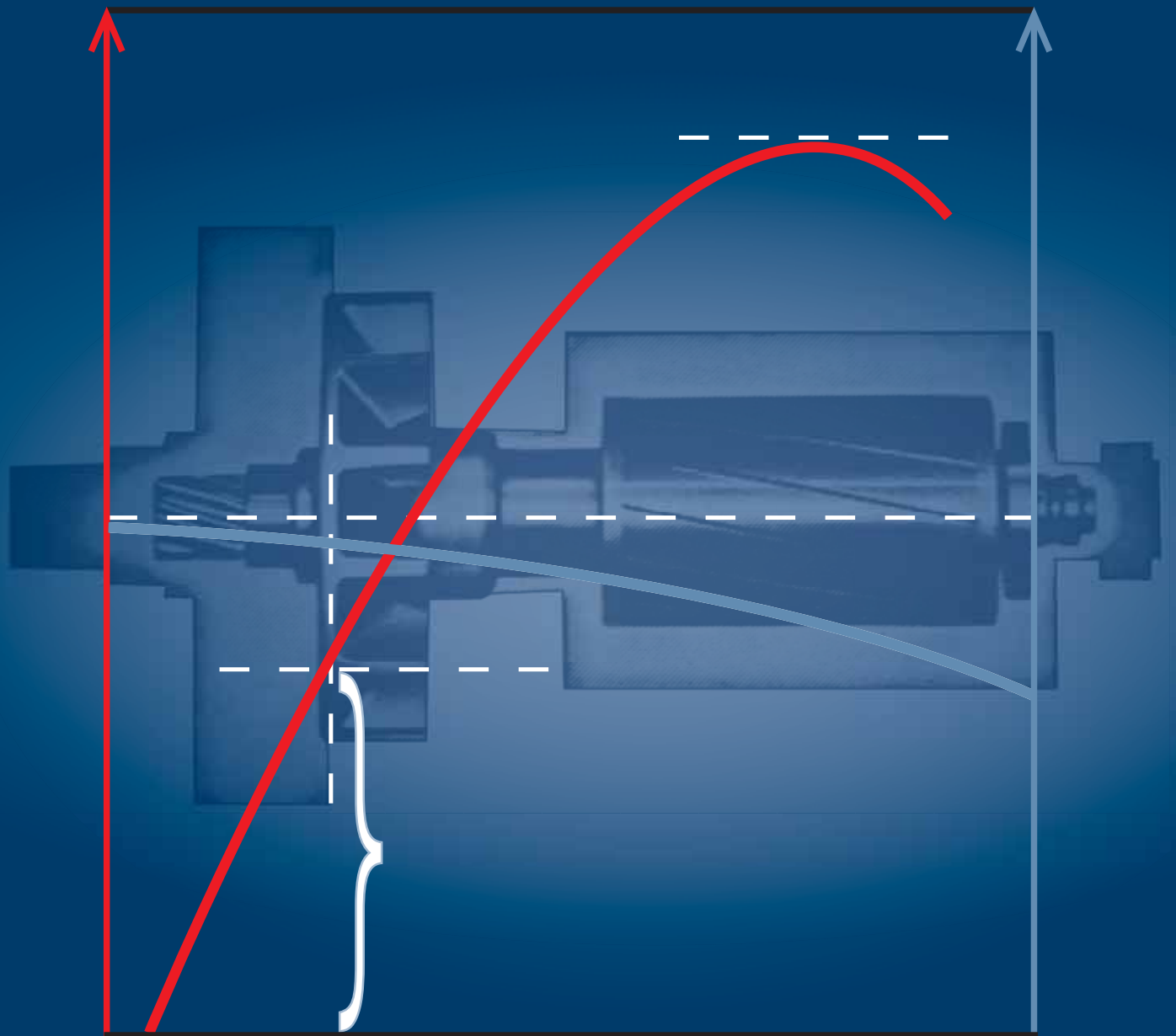

High-frequency Technology

A guide for the user

Robust technology

for heavy-duty continuous use

A high-frequency motor is a three-phase current motor with a short-circuit rotor. Its stator and rotor consist of a laminated sheet-metal bundle. If the stator winding of the motor is connected to the three-phase current supply, a magnetic field is created (rotary field), which runs through the motor due to the arrangement of the winding and which is dependent on the number of pole pairs and the frequency.

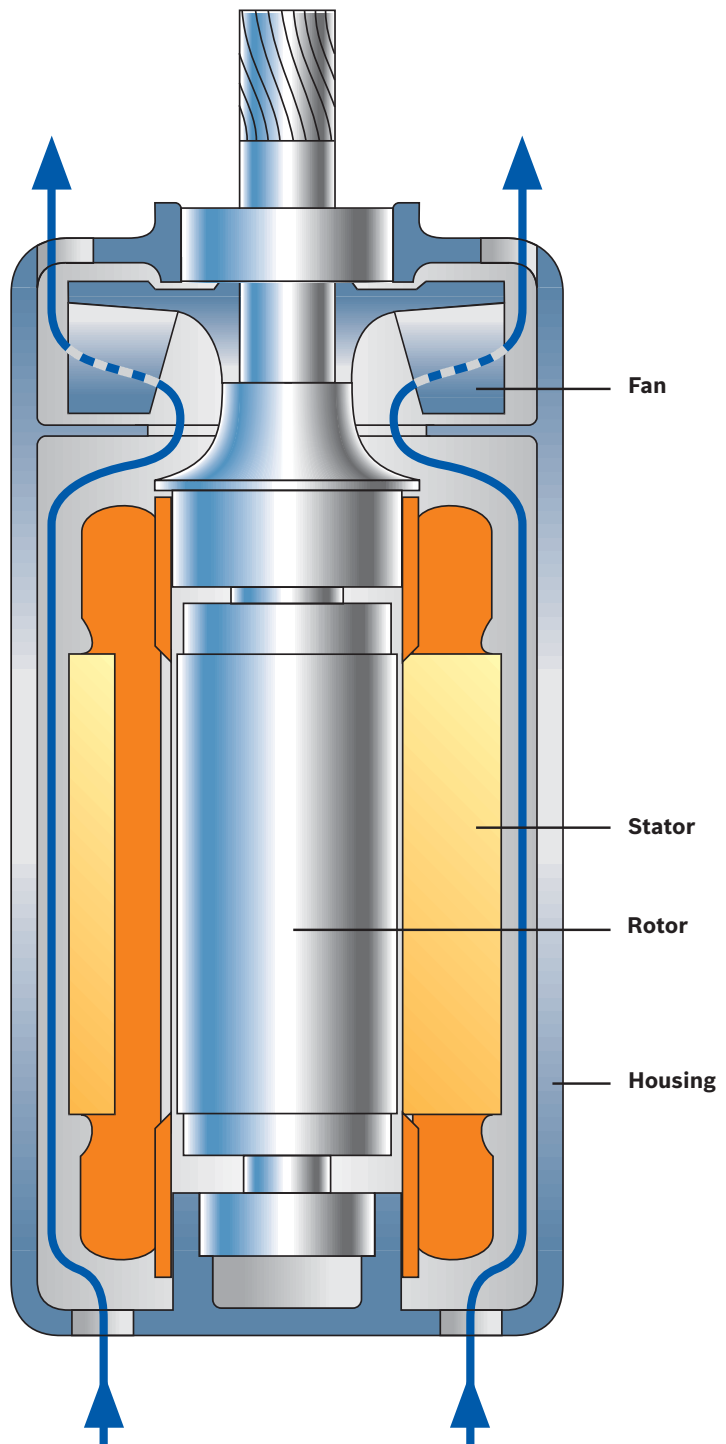

A real concept: High-frequency tools

How a good idea was consistently further developed: The designation 'high-frequency tools' came to be known through the market launch of the tools and was given to those powerful high-frequency tools with asynchronous motors, operated with three-phase current at an increased frequency of 200 or 300 Hz. In a physical sense, there is no real connection between these tools and genuine high-frequency technology, but they still came to be known under this name.

The operating frequency determines the power

Three-phase current with an increased frequency of 200 or 300 Hz allows for hand tools with high electrical powers at low motor weight. As the frequency of the three-phase current increases, the motor speed and therefore the power of the asynchronous motors increase at the same ratio. This is limited by the maximum permitted circumferential speed (working speed) of the tools. High-frequency tools operated at a frequency of 200 to 300 Hz have an optimum power/weight ratio

(Fig. 1). Larger gears are necessary if there are greater differences between motor and working speed. As a result, the weight saving on the three-phase drive is cancelled out by the greater weight of the transmission gear unit. High-frequency systems equipped only with grinders should be operated with 300 Hz. Applying three-phase current with increased frequency perfectly meets the demand for lightweight but powerful hand tools.

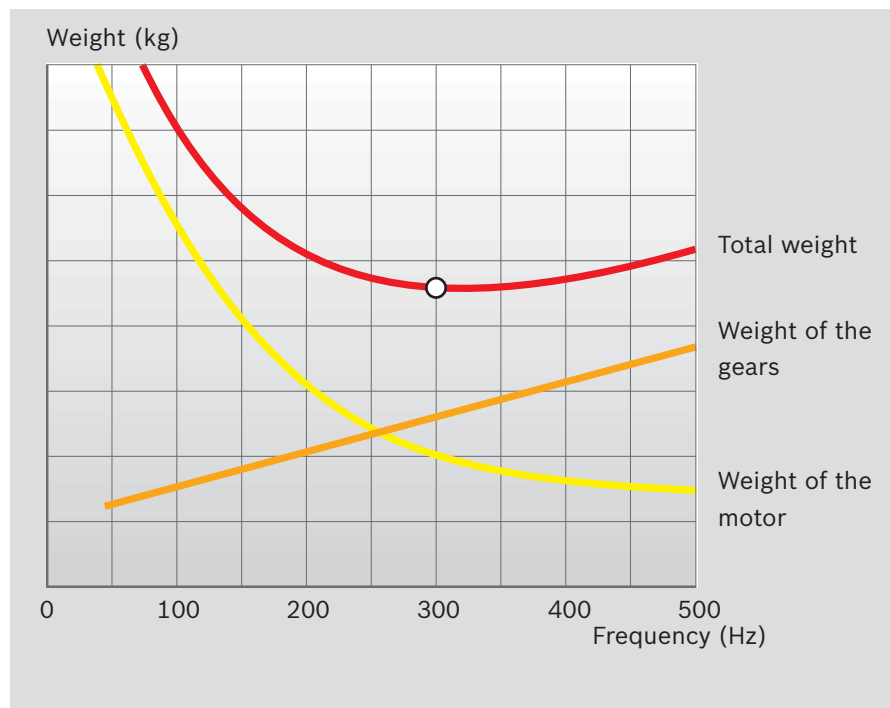

Fig. 1 The dependence of the motor and gear weight on the frequency at constant motor power and rated speed: The ratio of power to weight is optimal at 300 Hz.

Durable and reliable three-phase motors

A magnetic field forms in a three-phase current motor, which circulates through the motor. This is called a rotary field and is dependent on the number of pole pairs and frequency. When the smallest possible number of pole pairs is used, at a frequency of 50 Hz, for example, this results in a rotary field or rotor speed of 3000 rpm; at a frequency of 200 Hz: 12 000 rpm and at 300 Hz: 18 000 rpm.

Due to its low bearing clearance and the fixed stator winding, the motor is mechanically and electrically very reliable in operation and excels due to its smooth, low-vibration running. The drop in speed at rated load is only 3–5%, and the peak power is approximately 2½ times the rated power. Brief overloads are possible if they do not lead to the permitted winding temperature being exceeded.

Since hand tools are supposed to be as lightweight and powerful as possible, Bosch has opted for “dust protection with direct cooling” in its high-frequency motors. This approach combines the advantages of enclosed and open designs. The flow of cool air ensures good heat dissipation, while dust and dirt are simultaneously prevented from infiltrating the circulating system.

The design of Bosch high-frequency tools offers the following advantages in the application:

☒ **Optimum power at low weight**

In continuous operation, Bosch high-frequency tools achieve power of up to 400 watts per kilogram of machine weight. The peak powers can briefly deliver up to 2½ times the continuous power. These high reserves allow for a decisive improvement to performance.

☒ **Constant speed under load**

The drop in speed of Bosch high-frequency tools is only 3–5% at rated load (Fig. 2). This guarantees that the recommended cutting speeds can be fully exploited during grinding and drilling. The constant

cutting speed allows you to use bits more efficiently and, at the same time, to extend their lifetime.

☒ **Low maintenance costs at high load capacity**

Bosch high-frequency tools have a service-friendly design with a motor free of wearing parts. Even under the highest loads (e.g. in foundries), they are acknowledged as having a long lifetime and incur only low maintenance costs.

☒ **High degree of efficiency**

The high degree of efficiency of Bosch high-frequency tools allows for their cost-effective and environmentally friendly use in continuous operation.

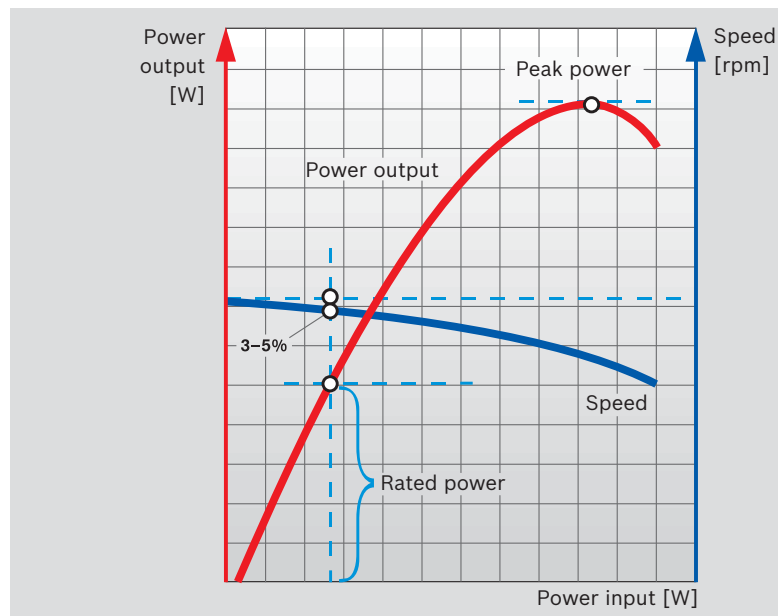

Fig. 2 Power and speed progression in relation to load torque

Electrical operating variables

An operating frequency of 300 Hz is recommended for a high-frequency tool system. The higher motor speed at 300 Hz is particularly advantageous for grinders at today's circumferential speeds. The higher motor speed results in higher machine power at the same weight. In all countries, a voltage of 135 V should be selected at 200 Hz and a voltage of 200 V at 300 Hz where possible.

The secondary power output of the frequency converter or its size is calculated as follows: The high-frequency tools provided are grouped according to motor size and quantity, so that you can add up their rated current consumptions. The total apparent power input of the tools can be calculated by multiplying the sum of the rated currents by the operating voltage and the factor $\sqrt{3}$. The formula is as follows:

$$S = \sqrt{3} \cdot U \cdot I = 1.73 \cdot U \cdot I$$

The resulting apparent power value still has to be multiplied by the demand factor G, in order to obtain the secondary power output of the converter. The demand factor G accounts for the degree of operation of all tools because usually not all tools are operated at the same time.

The following empirical values are available for the demand factor:

Car body construction	0.45
Engine construction	0.30
Apparatus construction	0.40
Mould and die construction	0.25
Steel construction	0.50
Foundry	0.60

These values only apply to larger numbers of machines. At a lower number of machines, the demand factor is determined by the largest, most frequently used tools.

When planning a high-frequency tool system, the frequency converter is always designed with a certain reserve. Especially when using small systems, it must be calculated such that the power output is at least twice as large as the rated power input of the most powerful high-frequency tool connected. This guarantees faultless start up of the tools. In the event of brief overload, the voltage drop in the frequency converter does not become too great.

Network groups

Operating frequencies and operating voltages:

Network group number	200 Hz	300 Hz
1	265 V	–
2	135 V	200 V
3	72 V	(110 V)
4	–	72 V
7	–	42 V
10	42 V	–

☒ Ideal network group

Calculation example for a high-frequency tool system:

In a foundry, 3 high-frequency angle grinders 0 602 332 034 with 230 mm diameter cutting discs and 3 high-frequency straight grinders 0 602 242 134 with 100 mm diameter grinding discs are to be used.

Calculation:
(Refer to pages 24 – 25 and 30 – 31 for current and voltage values.)

3 angle grinders, motor size 88	$3 \cdot 10 \text{ A} = 30.0 \text{ A}$
3 straight grinders, motor size 85	$3 \cdot 6.4 \text{ A} = 19.2 \text{ A}$
Sum:	49.2 A

This results in the apparent power:

$$\begin{aligned} S &= 1.73 \cdot U \cdot I \\ &= 1.73 \cdot 200 \text{ V} \cdot 49.2 \text{ A} \\ &= \text{approx. } 17 \text{ 023 VA} \\ &= \text{approx. } 17 \text{ kVA} \end{aligned}$$

This value still has to be multiplied by the demand factor $G \cdot 0.6$ for foundries:

$$\begin{aligned} \text{Converter apparent power} &= \\ S \cdot G &= 17 \text{ kVA} \cdot 0.60 = 10.2 \text{ kVA} \end{aligned}$$

In this case, a converter with 11 kVA secondary power is selected, so that there is still a power reserve of approx. 10%.

Layout of a system for high-frequency tools

Frequency converters with synchronous generator

The best solution technically for frequency converters is achieved by the combination of asynchronous motor and synchronous generator. The converters are single-shaft units with an asynchronous motor as drive motor and a brushless internal pole generator with fitted current generator.

The voltage difference between no-load and full-load with a small converter and a power factor of $\cos \varphi = 0.6\text{--}0.9$ is only approx. 3%; with large converters it is approx. 4%.

The synchronous converters are independent of voltage fluctuations in the primary three-phase supply network and are secured against short circuits. The rated voltage can be aligned using a potentiometer. They are also maintenance-free up to 20 000 hours of operation.

The formula for calculating the secondary frequency is as follows:

$$if_2 = f_1 \cdot p_2/p_1$$

f_1 = Primary frequency of the three-phase supply network

f_2 = Secondary frequency for high-frequency tools

p_1 = Number of pole pairs of the drive motor

p_2 = Number of pole pairs of the generator

As a rule, frequency converters with a power output of over 4 kVA should not be connected directly to the network, instead they should be connected by means of star delta switches. During direct activation, a brief surge of current occurs, which could overload the feed cables on converters over 4 kVA and trigger the upstream fuses. Using star-delta switching reduces the surge of current because, as opposed to direct switching, only a third of the current flows. The star-delta switch is used to switch the winding of the drive motor via star (switch-on process) to delta (operating position).

A frequency converter that is to be operated on a 400 V network with a star-delta switch absolutely must be designed for 400 V in a delta. If this kind of converter is only designed for 230 V in a delta, it can only be switched on directly in a star on a 400 V network, i.e. without star-delta switch. This absolutely must be taken into consideration when designing a new system.

Parallel operation of frequency converters

Frequency converters can be connected in parallel to increase the economic efficiency of the overall system and to compensate load peaks. In this way, you achieve optimum adaptation to the tools used. When using frequency converters with synchronous generator, different power grades can

be operated in parallel without special precautions.

Wattless current compensation

Each inductive consumer is subject to an inductive wattless current that does not perform any effective work, instead it only burdens the cables. Frequency converters and high-frequency tools are also inductive consumers.

Compensation of the wattless current on the secondary side of the converter requires considerable effort because each tool has to be compensated individually. Depending on the quantity and power of the individual high-frequency tools, a total power factor $\cos \varphi$ of 0.5–0.85 has to be expected. On the primary side of the frequency converter, the power factor $\cos \varphi$ can be improved considerably if the magnetising current from the drive motor and generator is compensated. By connecting correspondingly rated capacitors, it is possible to compensate the primary-side wattless power of the converter at no-load practically completely and under load to such an extent that a power factor greater than $\cos \varphi = 0.9$ is achieved.

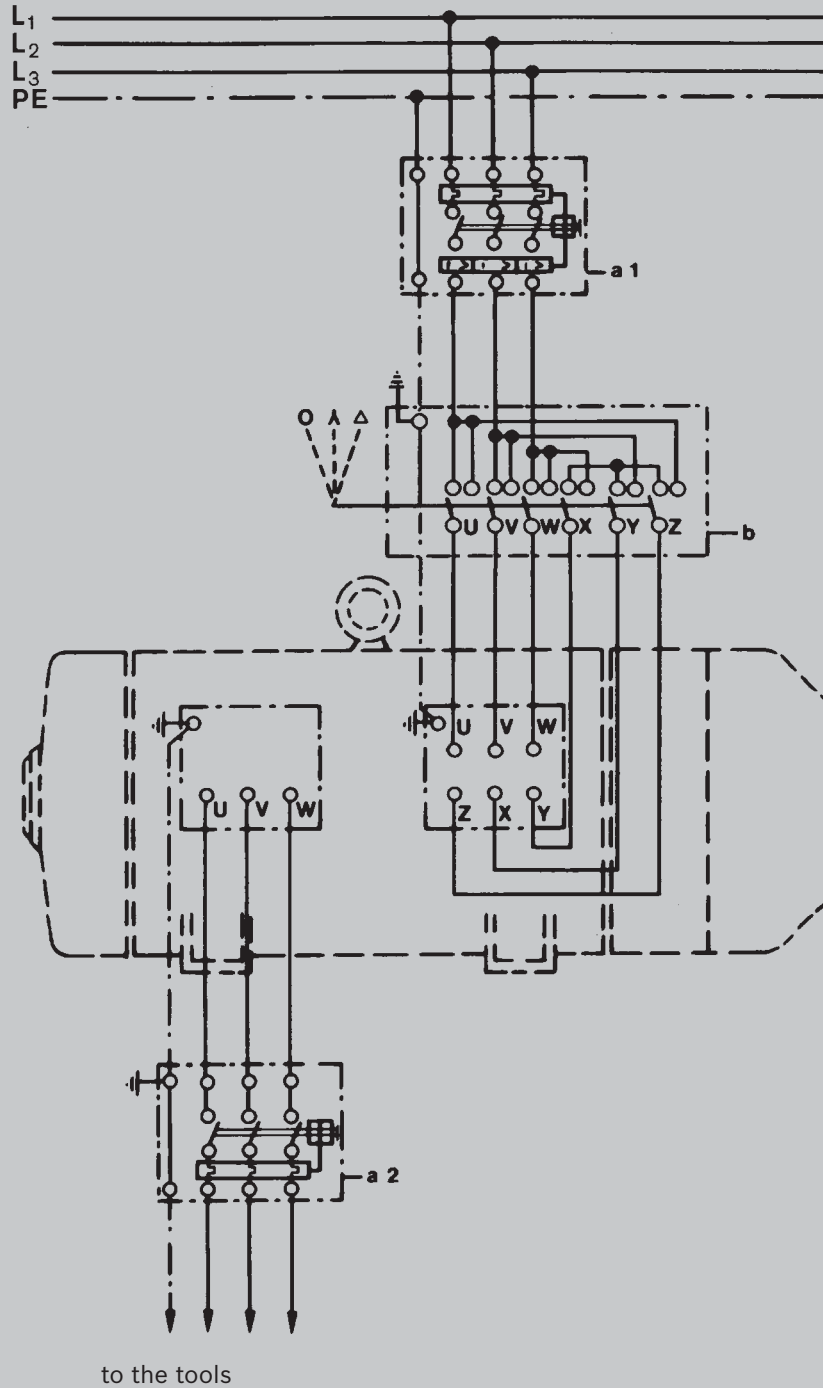

- a₁ = Motor protection switch with magnetic and thermal triggering
- a₂ = Motor protection switch with thermal triggering
- b = Δ switch, protective earthing as per VDE 0100

Fig. 3

Electrical safety

Electrical safety on high-frequency tools is provided by the protective earth conductor in accordance with EN 50144 to protection class I. On the star-connected secondary winding of the converter, the star or zero point is led out. This zero point is earthed (earth resistance $R_B \leq 2 \text{ ohms}$) and connected to the metallic housing of the high-frequency tools via the protective earth conductors, so that at an operating voltage of 265 V the hazard voltage between phase and earth in the worst case scenario is only

$$\frac{265 \text{ V}}{1.73} = 153 \text{ V.}$$

In contrast, at operating voltages of 135 V or 72 V it is only

$$\frac{135 \text{ V}}{1.73} = 78 \text{ V or}$$

$$\frac{72 \text{ V}}{1.73} = 42 \text{ V}$$

The effectiveness of the protective earthing is guaranteed by using correspondingly robust plug connections, which are imma-

culate in their electrical design, and hard-wearing cables. Careful maintenance is equally important. The high-frequency tool itself must meet the high requirements of industrial manufacturing in terms of its design.

It is standard practice to follow the above description, i.e. the "zeroing" protective measure as per VDE 0100-§ 10 N.

The possible protective measures can be subdivided as follows:
1.0 in protective measures without switch-off device

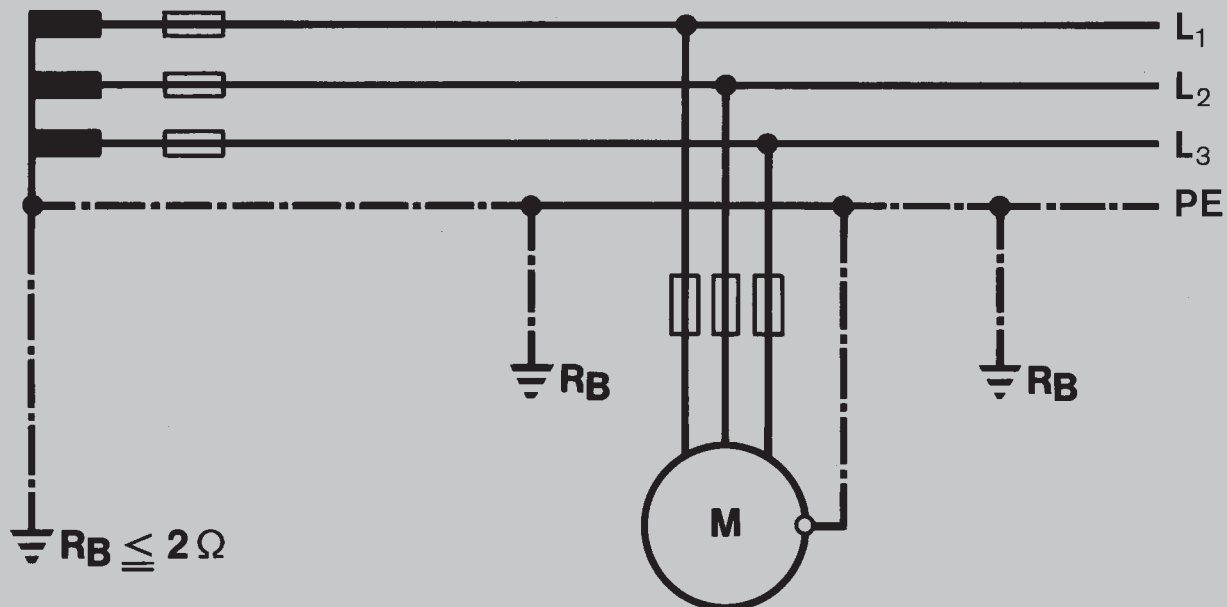

Fig. 4

- 1.1 Protective insulation (VDE 0100-§ 7 N)
- 1.2 Extra-low voltage 42 V (VDE 0100-§ 8 N)
- 1.3 Protective isolation (VDE 0100-§ 14 N)
- 2.0 in protective measures with switch-off device
- 2.1 Protective earthing (VDE 0100-§ 9 N)
- 2.2 Zeroing (VDE 0100-§ 10 N)

In cases 2.1 and 2.2, switch-off is performed by fuses or corresponding station protection switches with thermal-magnetic triggering.

The greatest possible protection is achieved by additionally using residual current protective switches.

Protective insulation as per 1.1 is not introduced on high-frequency tools. The extra-low voltage as per 1.2 is only used in special cases if it cannot be bypassed due to existing regulations.

It is very problematic when transferring high levels of power due to the high currents with regard to cable cross-section, switch, plug, etc. An exception to this are small screwdrivers. It is then better to use the “protective isolation as per 1.3”, in which each tool requires its own isolating transformer. The use of protective isolation should be restricted only to cases where it is absolutely necessary.

In the main, the “zeroing as per 2.2” protective measure should be observed somewhat more closely because it is predominantly used for high-frequency tool systems. Zeroing is intended to prevent constantly excessive touch voltages at system parts not belonging to the operating circuit (see Fig. 4); it requires a directly earthed central point or star point conductor and is established by means of connection of the system parts that are to be protected to the neutral conductor or to a special protective

earth conductor connected to the neutral conductor.

Using the “zeroing” protective measure thus ensures that faulty parts of the system are switched off because the fuse directly upstream of the fault position is active.

To ensure that the fuse really does respond, certain zeroing conditions in accordance with VDE 0100-§ 10 N must be met. The most important zeroing condition is as follows: the cross-sections

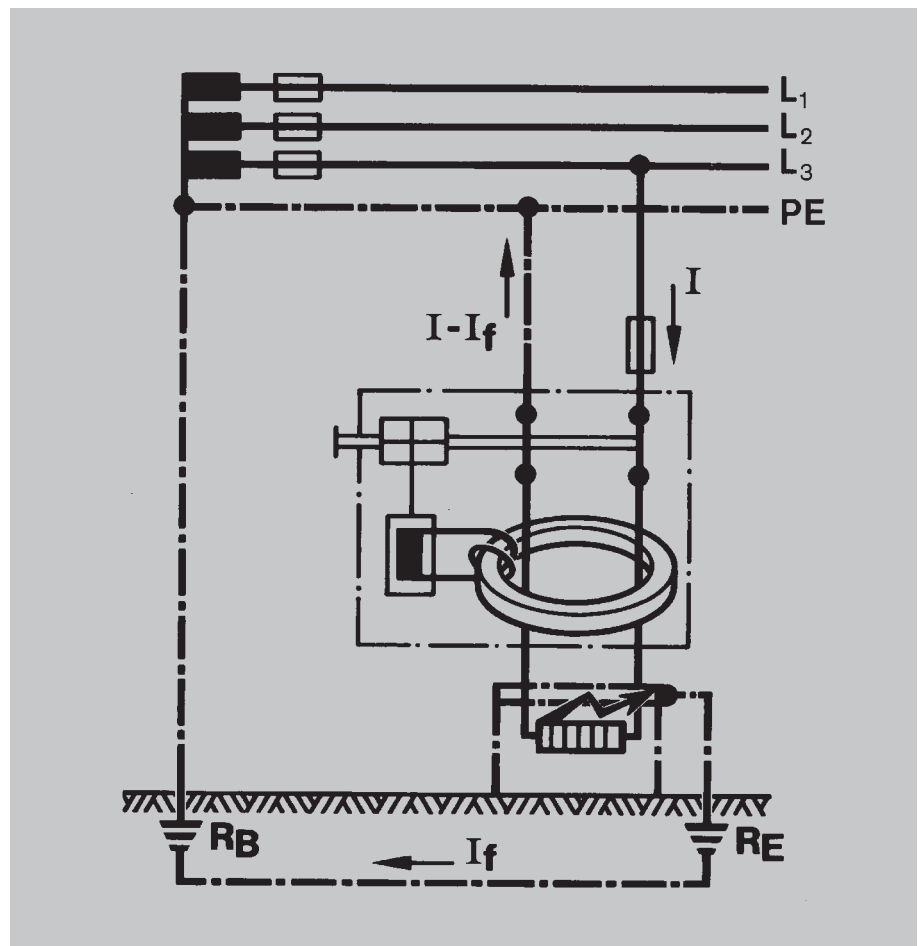

Fig. 5

of the cables between current generator or transformer and current consumer must be rated such that at least the breaking current I_A of the next upstream overload protection element as per Panel I VDE 0100-§ 9 N flows when at any position of the cable network a complete short-circuit occurs between an outer conductor and the neutral conductor. In addition, residual current protective switching in accordance with Fig. 5 can be used (to simplify this, the drawing shows single-phase current). The residual

current protective switch obtains its pulse from a current transformer which all feed cables including neutral conductor are fed through. The secondary coil of the current transformer delivers the operating current for the relay coil of the residual current protective switch. The cables enclosed by the current transformer generate an alternating magnetic field in the transformer core when the sum of all currents is not cancelled out (Fig. 7).

In the fault-free status of the residual current protective switch, the

current flowing to the consumer is equal to the current flowing back from it. The currents thus cancel each other out. No induction takes place onto the secondary coil of the current transformer, so that the relay coil of the residual current protective switch remains currentless (Fig. 5).

In the faulty status of the residual current protective switch, a residual current is discharged via the earth; in the current transformer not all currents cancel each other out, so that induction occurs. Voltage is induced on the secondary side of the transformer. The relay coil of the residual current protective switch responds (Fig. 7).

At 265 V/200 Hz three-phase current, there are residual current protective switches for 45 mA. Residual current protective switches for three-phase current of other voltages and frequencies must be requested separately from relevant manufacturers!

The schematic illustration of a residual current protective switch is shown in Fig. 6. To satisfy the regulations and certain conditions in other countries, there are Bosch high-frequency tools for various operating voltages:

265 V, 135 V, 72 V, 42 V at 200 Hz; 200 V, 72 V, 42 V at 300 Hz. At low voltages, only few high-frequency tools should be used in the vicinity of the frequency converter because the currents occurring at greater power and low voltage require excessively large conductor cross-sections.

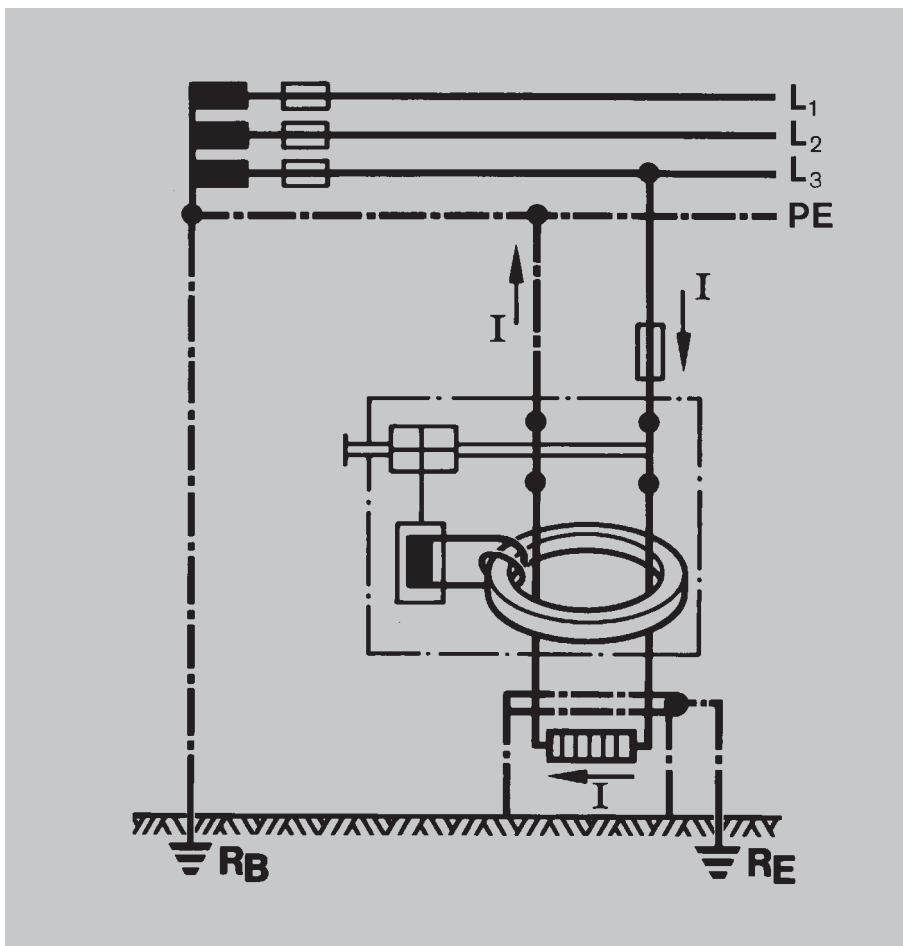

Fig. 7

The distributor network

The distributor network must not have any connections to the existing 50 Hz supply network. For this reason, special CEE plug connections as per DIN 49462/63 and DIN 49465 are also prescribed for frequencies between 100 and 300 Hz.

The housing colour of the plugs, coupling and wall sockets is green. The different design of these plug connections guarantees that existing 50 Hz plug connections can be combined neither with plugs nor with coupling sockets.

Depending on requirements, movable or fixed cables can be used for the distributor network between the frequency converter and the individual high-frequency tools.

The transfer of greater powers at

low voltage is uneconomical in widely ramified systems. Either high installation costs are incurred due to the large conductor cross-sections or transformers are required, which do not reduce the higher voltage until the operating location of the tool.

In light of the prerequisite for constant transfer capacity, defined voltage drop and consistent cable length, the change of the cable cross-section is square to the voltage, i.e. half of the voltage results in four times the conductor cross-section.

The required cross-sections of the distribution network can easily be determined using illustrations 8 to 10. The conductor cross-sections

are calculated subject to the permitted voltage drop of 5% from the ohmic resistance, the permitted heating and the voltage drop from the inductive resistance. The illustrations should be read as follows:

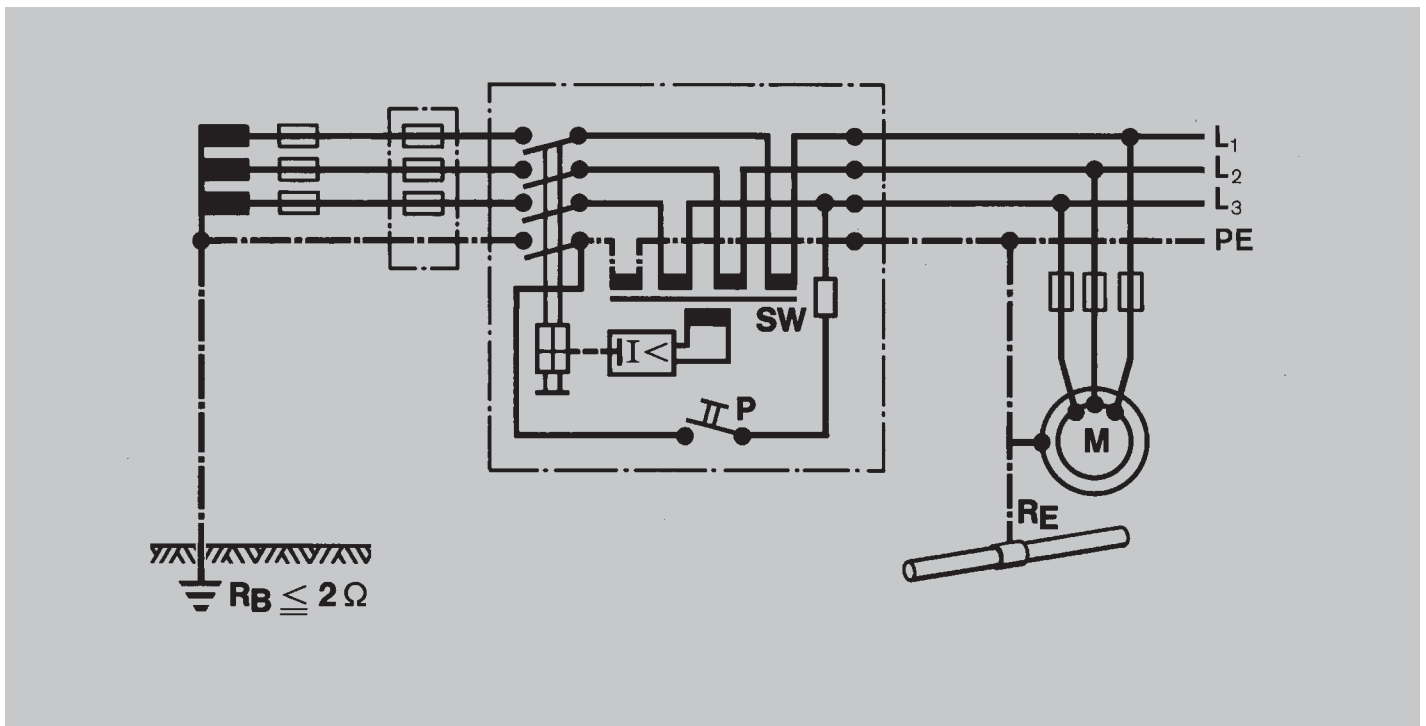

Fig. 6

Fig. 8:
Cable cross-section in relation to voltage and cable length

With the value of the powers to be transferred, you find the type of current and go from left to right horizontally until you meet the intersection with the line for the voltage. From there, you go down vertically until you meet the intersection with the line for the cable length (straight length) and then horizontally again to the left or right.

Fig. 9:
Cable cross-section in relation to voltage and power factor

The heating of the cross-section determined in Fig. 8 is now checked. With the value of the power to be transferred, you go from the left horizontally until you meet the intersection with the line for the voltage, then down vertically until you meet the intersection with the line for the power factor $\cos \phi$, and finally horizontally to the right where you can then read the cross-section depending on the type of cable.

Fig. 10:
Cable cross-section in relation to frequency and inductive resistance

If the result at three-phase current from Fig. 8 and 9 is a cross-section of over 10 mm², then you go

to Fig. 10 with the exact ascertained value to take into consideration the inductive voltage drop. There you go up vertically from the horizontal base line until you meet the intersection with the curve for the frequency and then horizontally to the left or right. Of the cable cross-sections ascertained, the larger one is authoritative for the rating of the cable. The inductive resistance takes particular effect when dealing with larger cable cross-sections.

These are, in turn, required at low voltage or higher frequency. A power factor $\cos \phi$ of 0.7 for the consumers has been made the basis for calculation of the curves of Fig. 10. In single-phase alternating current systems with a power factor $\cos \phi = 1$, the inductive resistance can also be disregarded for larger cable cross-sections.

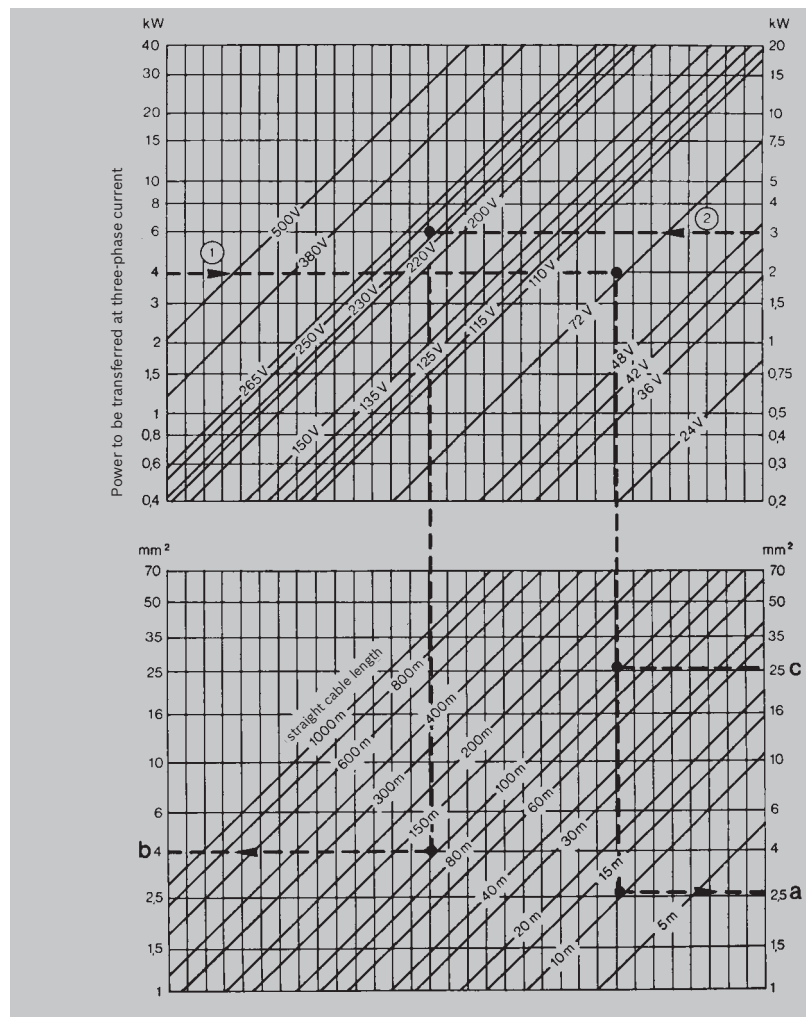

Fig. 8

Example 1

Transfer of 4 kW, 72 V three-phase current, $\cos \phi = 0.8$ Cable length (straight): 10 m Ascertained cable cross-section as per Fig. 8: 2.75 mm² Ascertained cable cross-section as per Fig. 9: 4.8 mm² (selected cross-section 6 mm²). The cable cross-section of 2.75 mm² ascertained using Fig. 8 and 9 is not sufficient; it would lead to excessive heating of the cable. There is no need to check according to Fig. 10 because the cross-section is less than 10 mm².

Example 2

Transfer of 3 kW, 220 V single-phase alternating current $\cos \phi = 0.9$ Cable length (straight): 100 m Ascertained cable cross-section as per Fig. 8: 4 mm² Ascertained cable cross-section as per Fig. 9: 0.9 mm² According to Fig. 8, a cross-section of 4 mm² is required. This is authoritative because the result for the cable according to Fig. 9 is only 0.9 mm² and there is therefore no major risk of heating.

Example 3

Same as Example 1, but 200 Hz three-phase current at 100 m cable length. Ascertained cable cross-section from Fig. 8 is 27 mm². This value must be checked according to Fig. 10. In this case, the larger cross-section of 50 mm² must be selected.

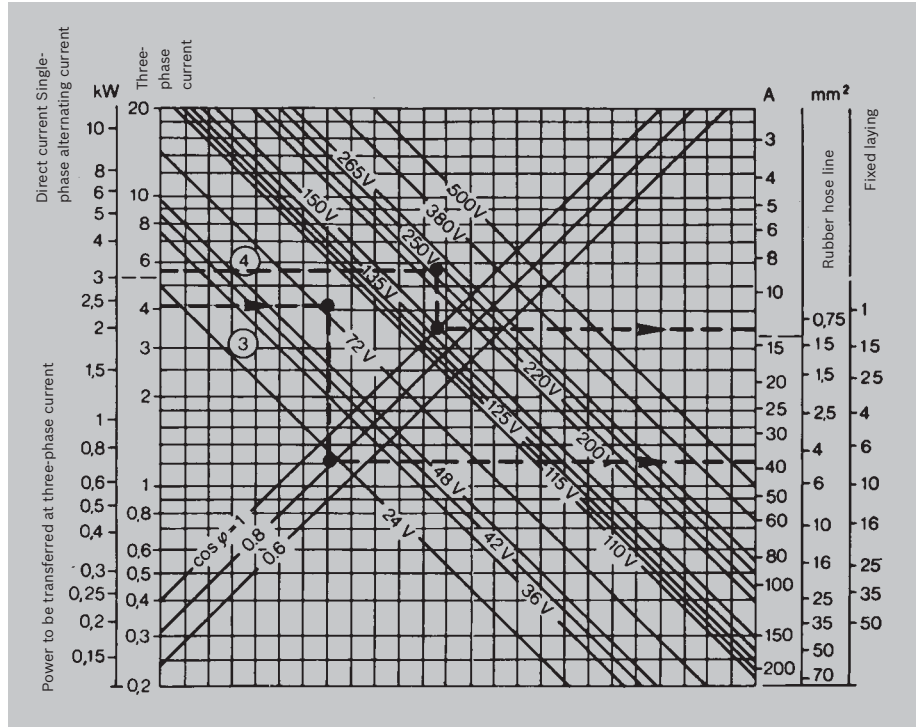

Fig. 9

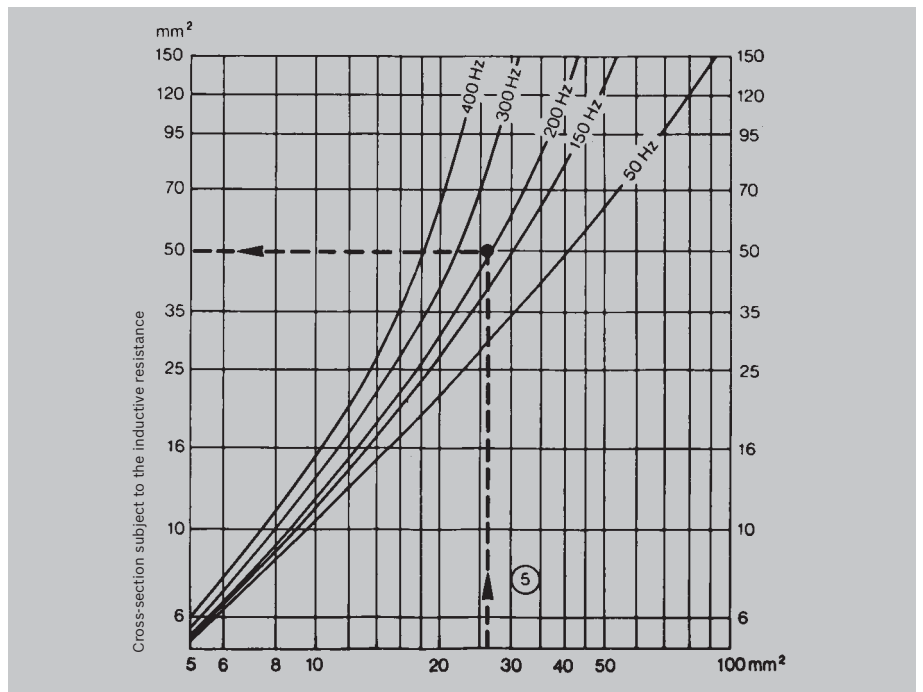
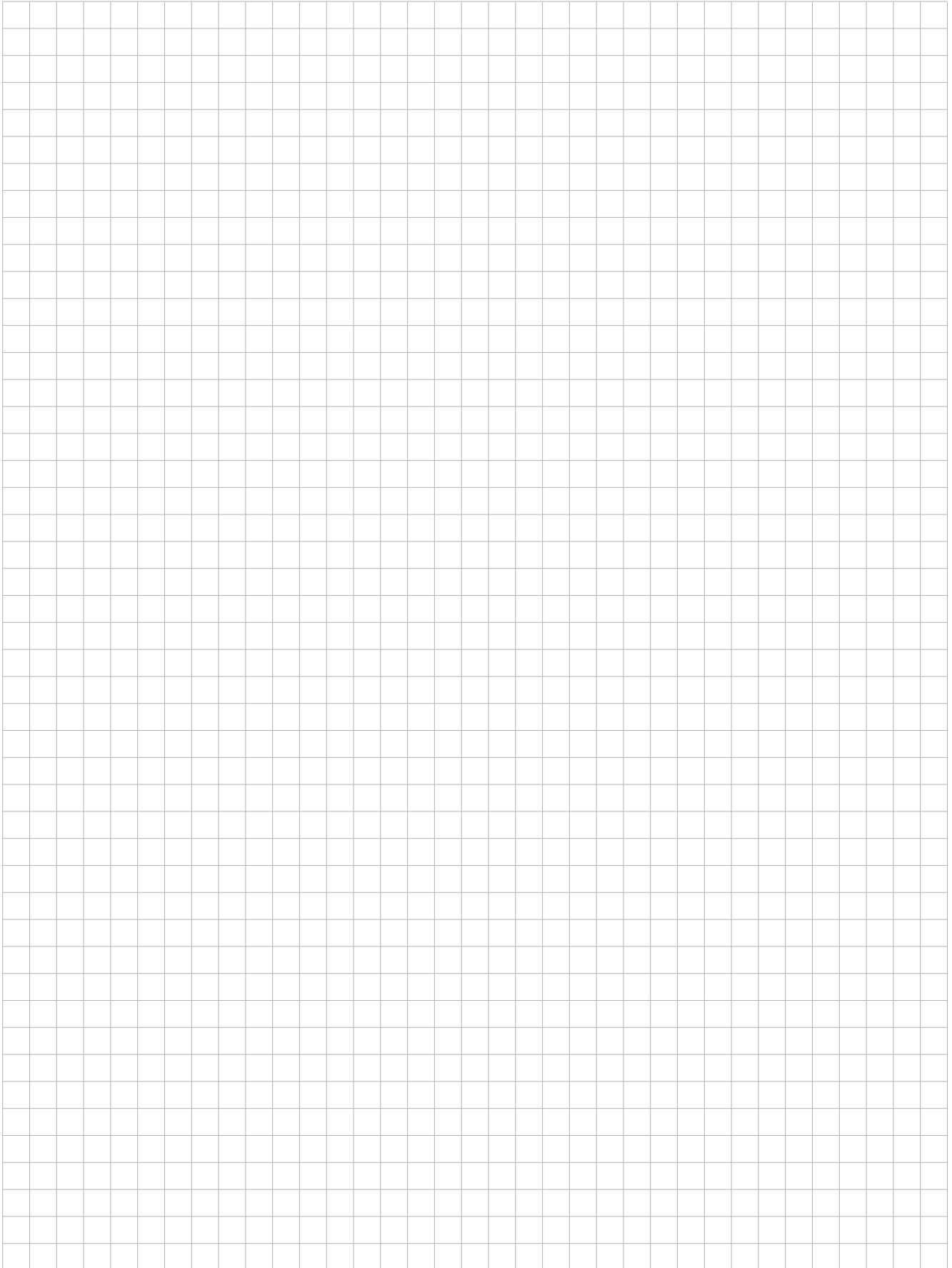

Fig. 10

If you have any questions about high-frequency technology or about using Bosch high-frequency tools, the Bosch customer consultants with all of their know-how will be happy to help you.

Notes Page



Bosch Service Quality



The Bosch CD-ROM Service information system

provides information on Bosch Power Tools over the last 25 years – including spare parts lists and exploded drawings and saves you time and money in spare parts management.



The Bosch Fax Service

offers direct, inexpensive access to important service documents such as spare parts lists, exploded drawings and forms. Information can be called up round the clock – even on Sundays and bank holidays.



The Bosch Spare Parts Service

guarantees, in 99% of all cases, that the spare part you require is in stock, ensuring you can quickly return to your work.



The Bosch Recycling Service

offers environmental protection that anybody can actively take part in.

Bosch production tools, cordless tools and battery packs that are past their lifetime are taken back at no charge via specialist retailers or directly and sent for recycling.

Robert Bosch GmbH
Power Tool Division
Marketing, Sales Production Tools

Max-Lang-Straße 40-46
D-70771 Leinfelden-Echterdingen
e-mail: ProductionTools@de.bosch.com
www.boschproductiontools.com

1 619 DA0 917 (01.10)
Printed in Federal Republic of Germany.
Imprimé en République Fédérale
d'Allemagne. Subject to technical
alterations. No liability is accepted
for printing errors.